

Comp-304 : Statecharts Lecture 15

Alexandre Denault
Original notes by Hans Vangheluwe
Computer Science
McGill University
Fall 2007

Statecharts

- Used to model behavior of Reactive Systems (event driven, react to internal and external stimuli)
- Visual formalism but formal and rigorous for
 - ◆ documentation
 - ◆ analysis
 - ◆ simulation
 - ◆ code generation
- Solves FSA problems:
 - ◆ flat -> hierarchy -> re-use
 - ◆ represent large number of transitions concisely
 - ◆ represent large number of states concisely

- A Statechart is a Deterministic Finite State Automata (FSA, DFA) plus:
 - ◆ Depth
 - ◆ Orthogonality
 - ◆ Broadcast
 - ◆ History

Statechart References

- David Harel. Statecharts: **A Visual Formalism for Complex Systems**. Science of Computer Programming. vol. 8. 1987. pp. 231 - 274.
- David Harel and Amnon Naamad. **The STATEMATE semantics of statecharts**. ACM Transactions on Software Engineering and Methodology (TOSEM) vol. 5. Issue 4. October 1996. pp.293 - 333.
- Michael von der Beeck. **A comparison of statechart variants**. In **Formal Techniques in Real-Time and Fault-Tolerant Systems**. L. de Roever and J. Vytopil, Eds. Lecture Notes in Computer Science vol. 863. Springer-Verlag, New York, pp. 128 - 148. 1994
- Michael von der Beeck. **A structured operational semantics for UML-statecharts**. Software and Systems Modeling. Volume 1, No. 2 pp. 130 - 141 . December 2002.
- Statechart revisions in UML 2.0 (www.omg.org).

Statechart Tools

- STATEMATE [<http://www.ilogix.com/products/magnum/index.cfm>]
- Rhapsody [[http://www.ilogix.com/products/rhapsody/rhap inc.cfm](http://www.ilogix.com/products/rhapsody/rhap%20inc.cfm)]
- Rational Rose [<http://www.rational.com>]
- Stateow [<http://www.mathworks.com/products/stateflow/>]
- BetterState Lite
[<http://www.windriver.com/products/html/betterstate.html>]
- XJTek [<http://www.xjtek.com/products/xjcharts/>]
- Poseidon for UML [<http://www.GentleWare.com>]
- ArgoUML [<http://argouml.tigris.org/>]
- visualSTATE [<http://www.iar.com/Products/VS/>]
- SVM [<http://msdl.cs.mcgill.ca/people/xfeng/research.html>]

Finite State Automaton

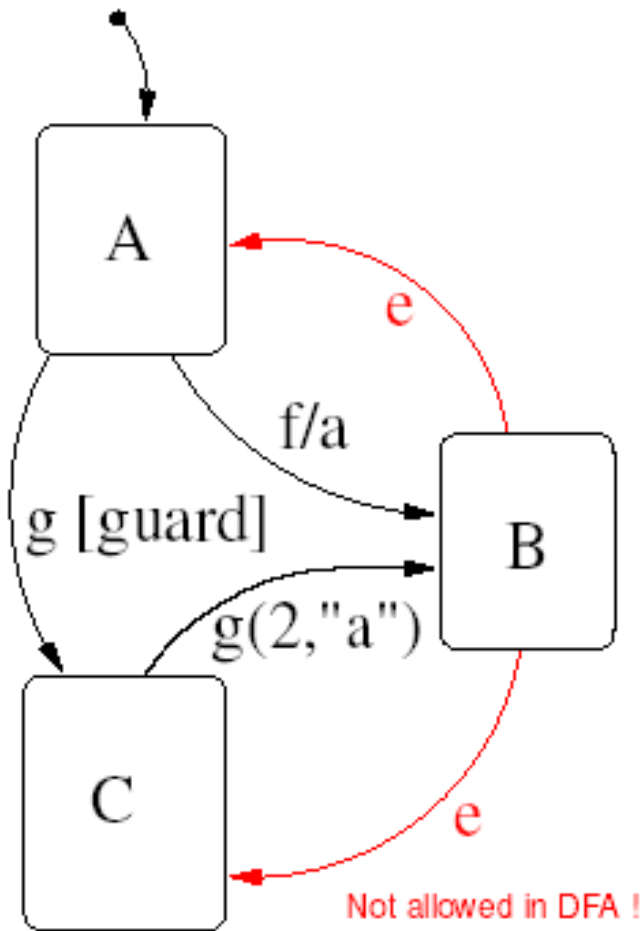

State

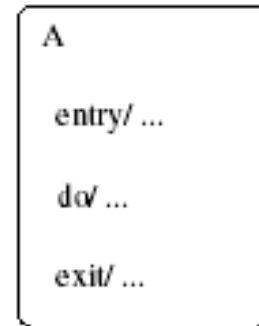
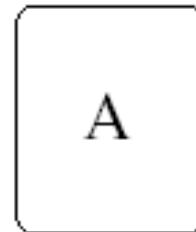

Default state (pseudo state)



transition

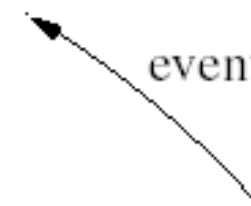

event(params) [guard] /output_action(params)

Statechart with depth

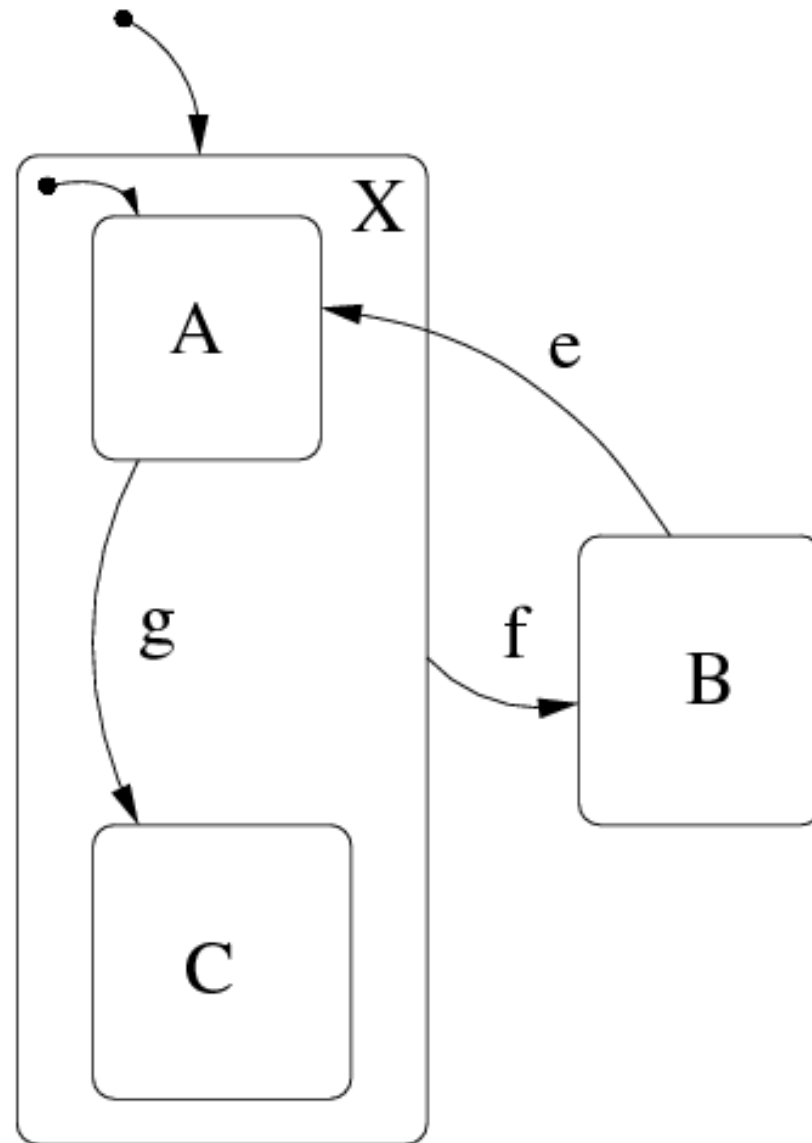

Depth

Statechart with depth

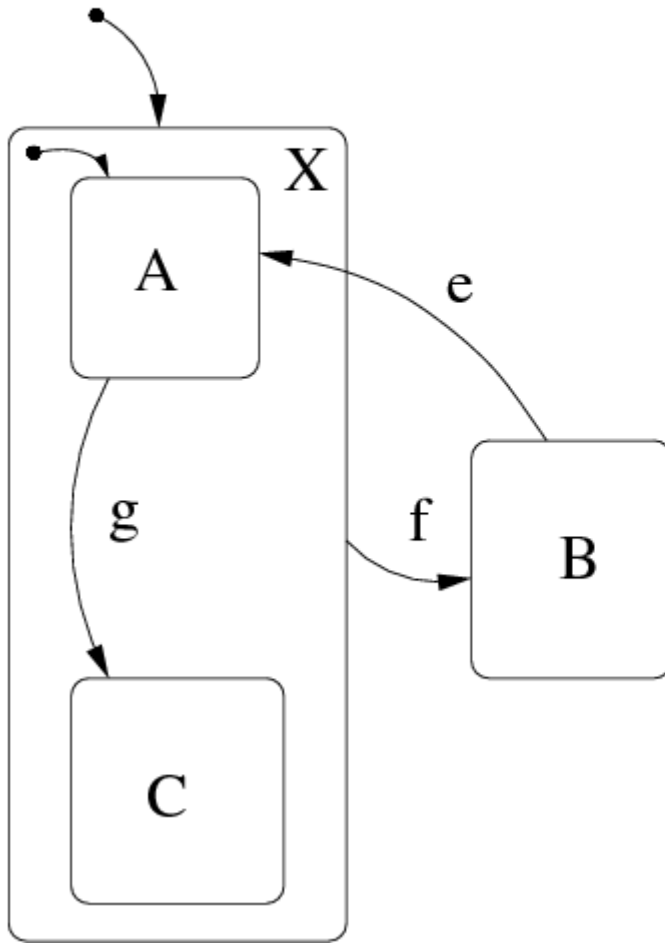

give meaning
by "flattening"



State automaton

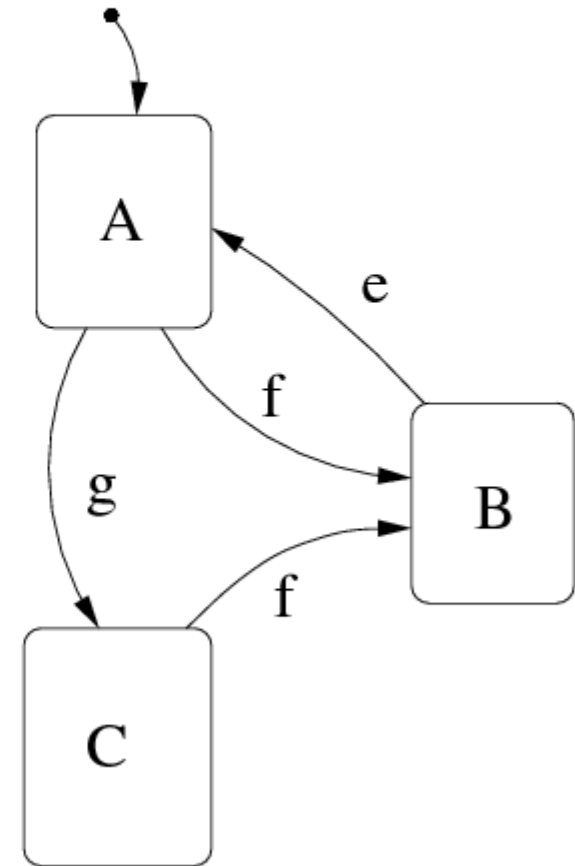

Depth and Determinism

Statechart with depth

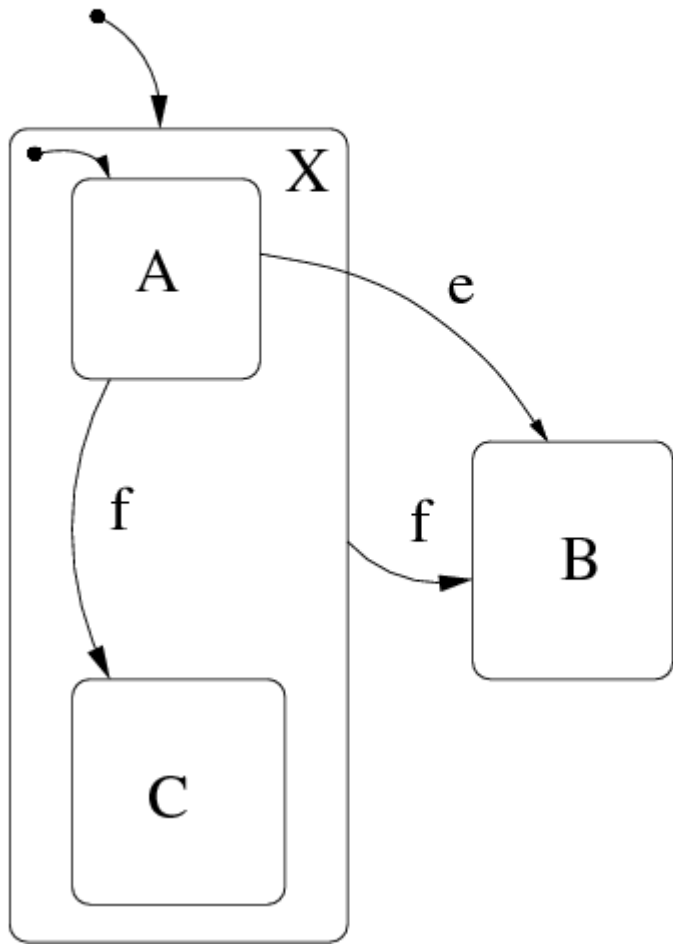

give meaning
by "flattening"



State automaton (non deterministic)

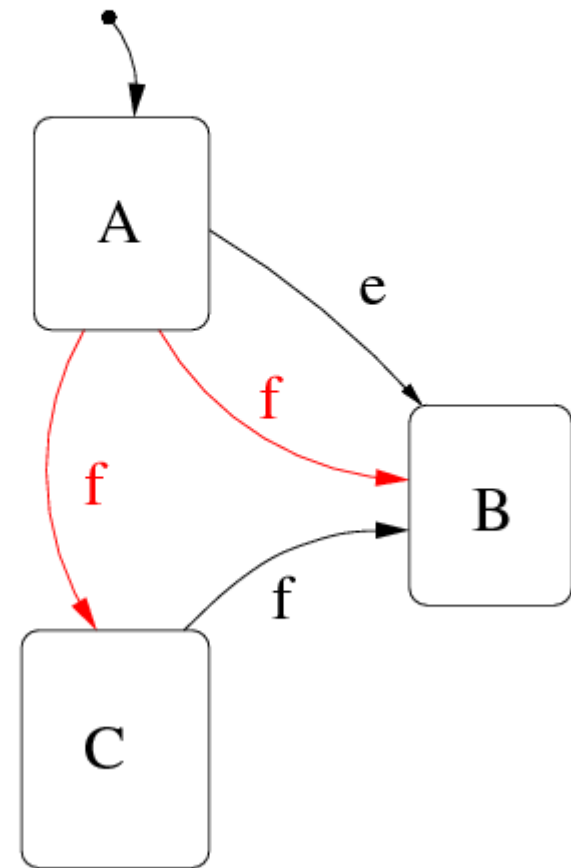

Depth and Determinism (cont.)

State automaton (non deterministic)

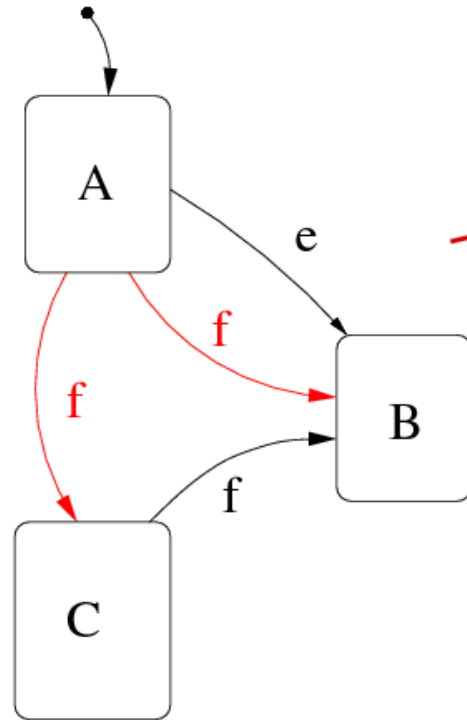

Deterministic state automaton
inner transition first (UML)

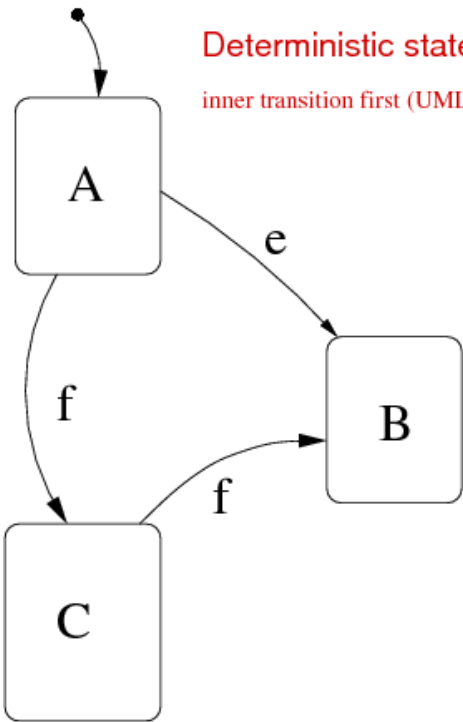

Deterministic state automaton
outer transition first (STATEMATE)

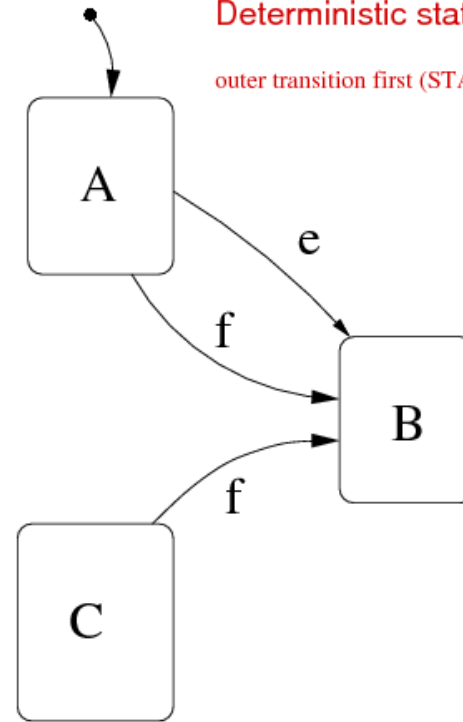

Why inner-first?

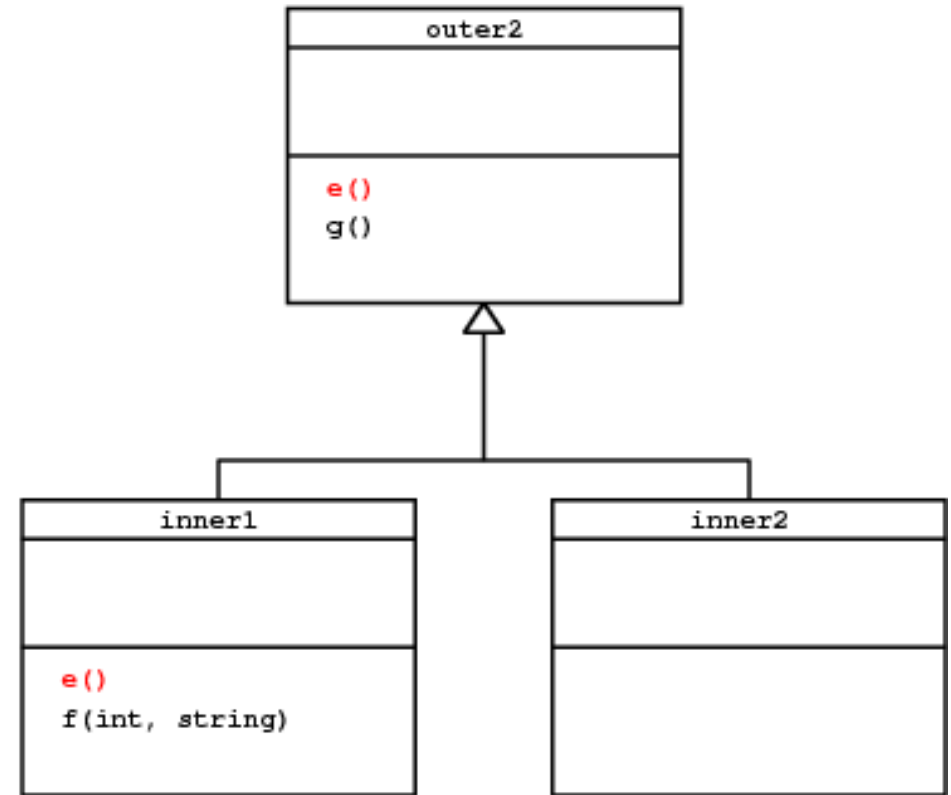
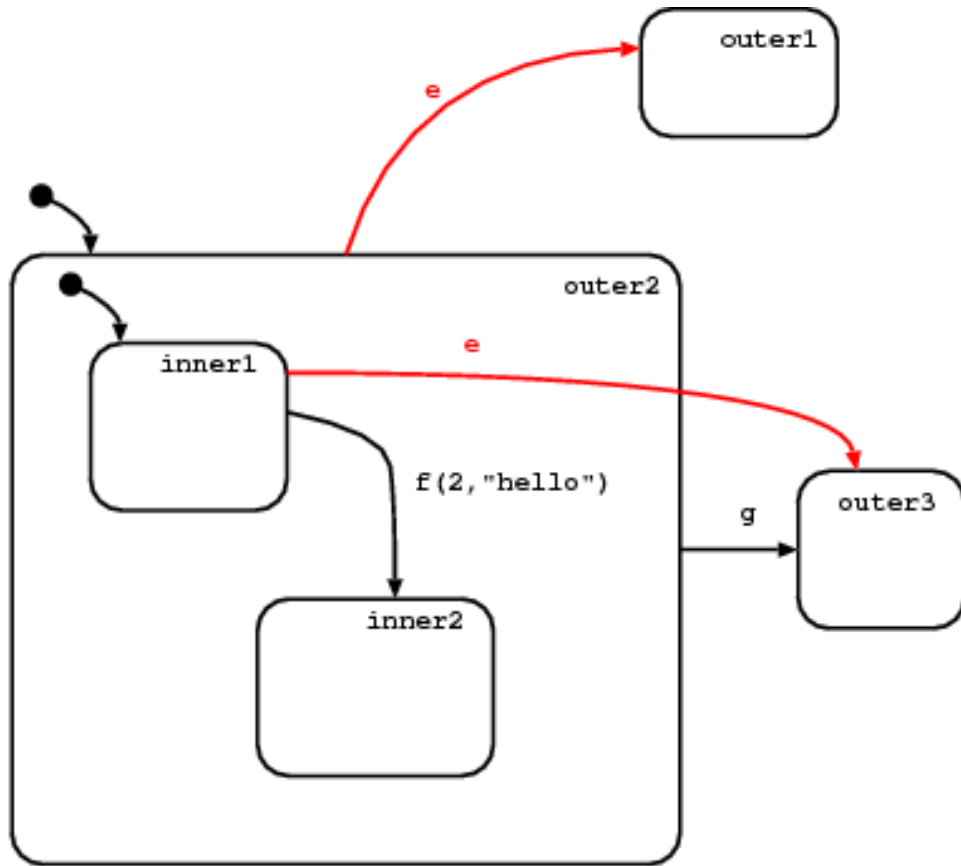

Orthogonality

Statechart with Orthogonal Components

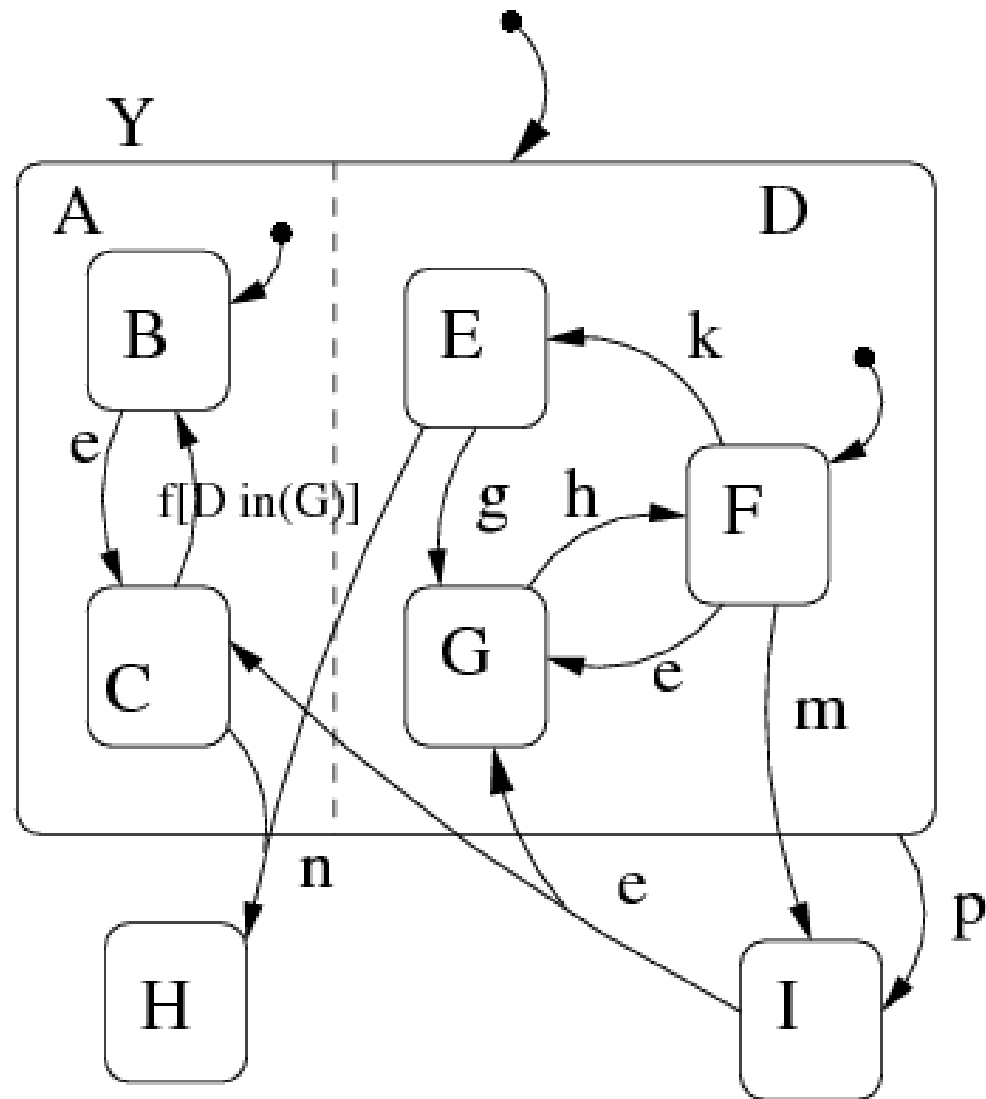

Orthogonality

meaning \longrightarrow

Statechart with Orthogonal Components

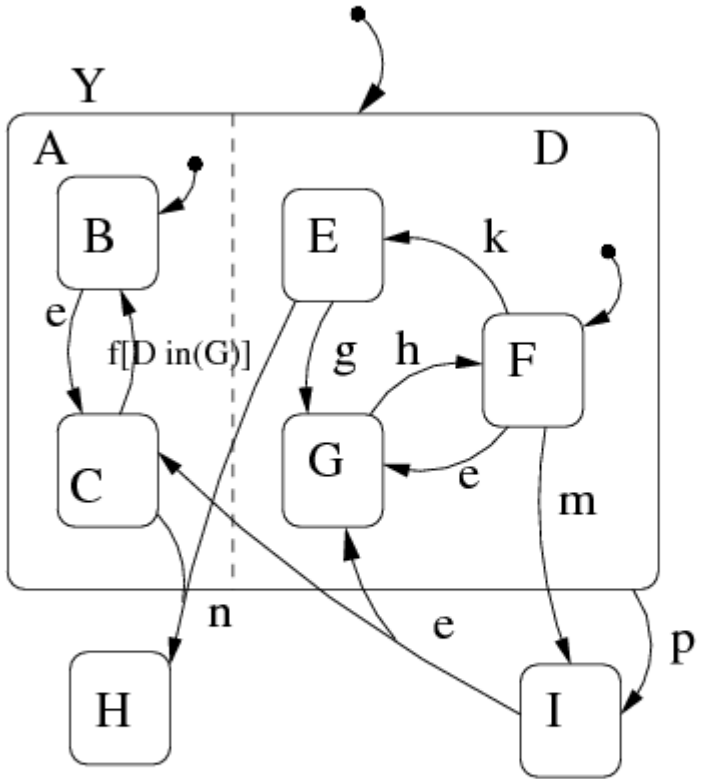

State Automaton

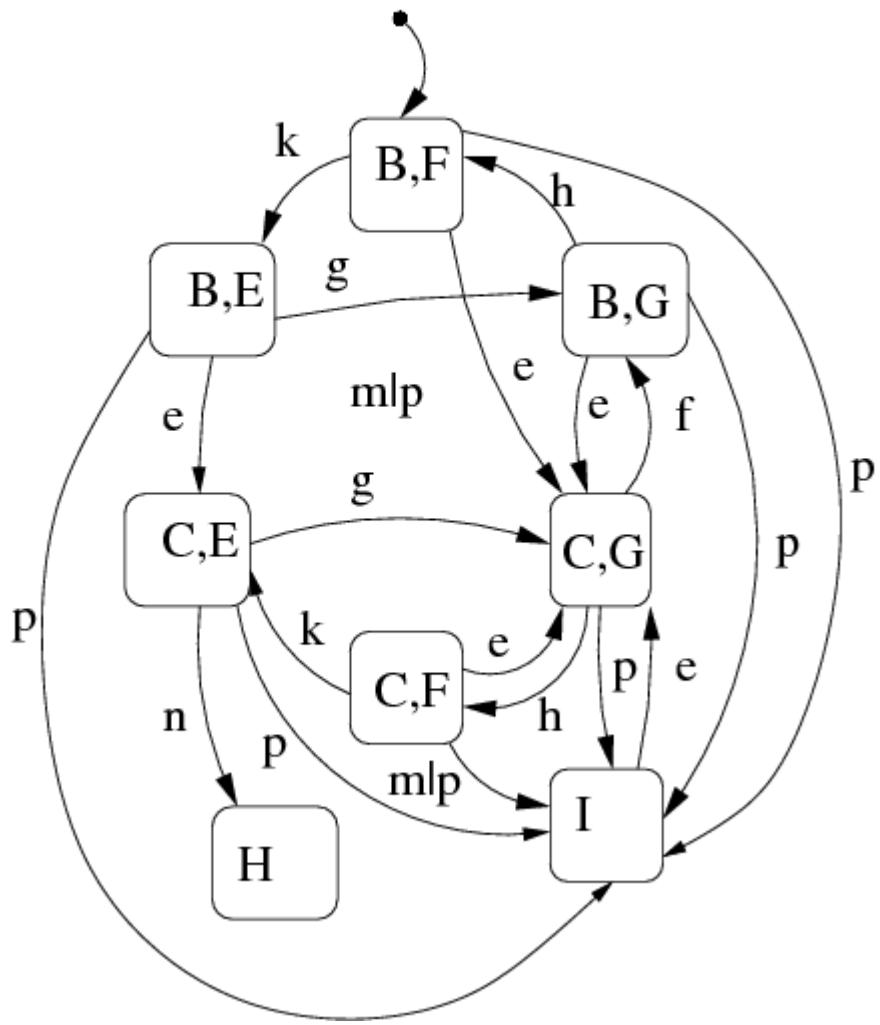

Broadcast (output)

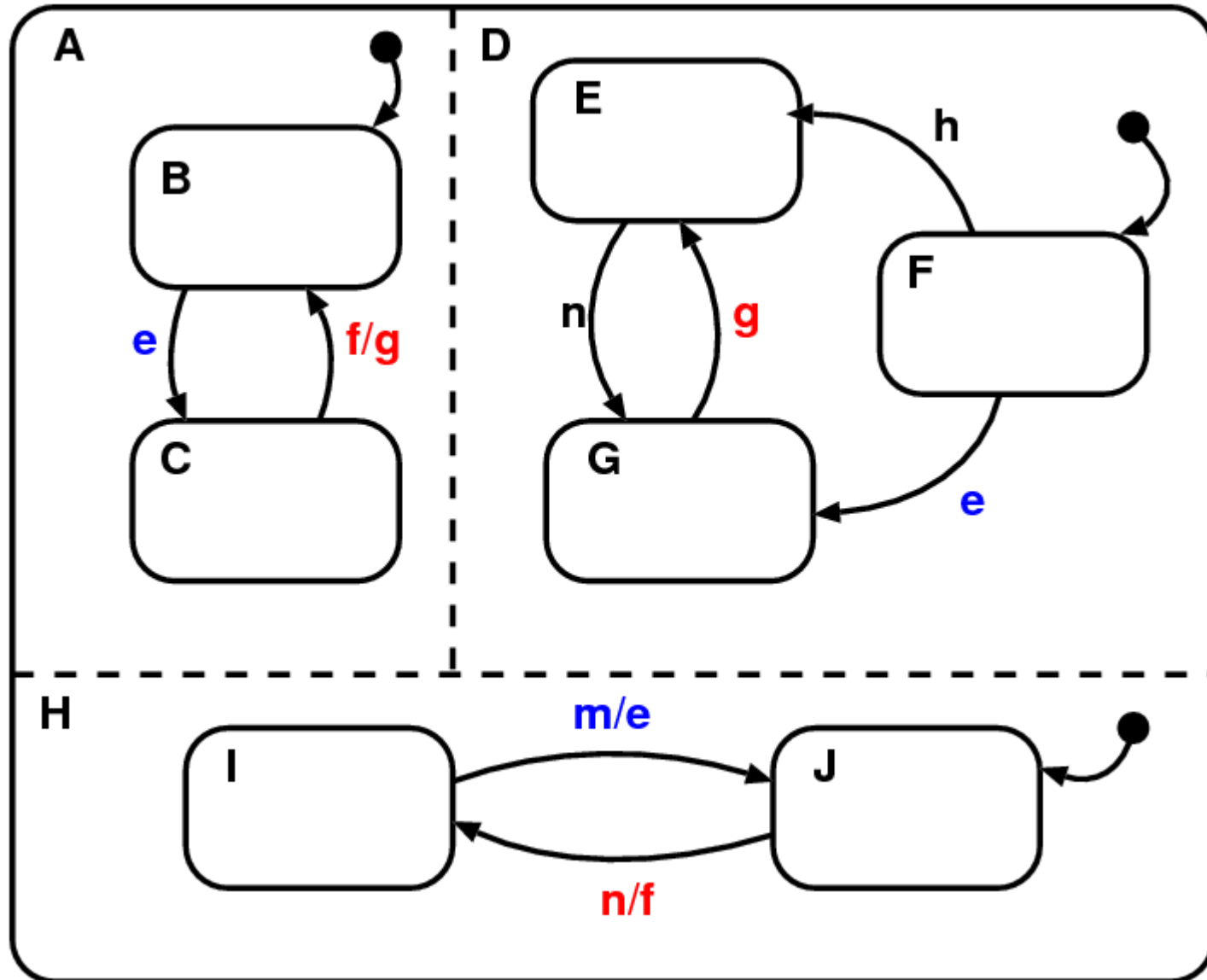

History

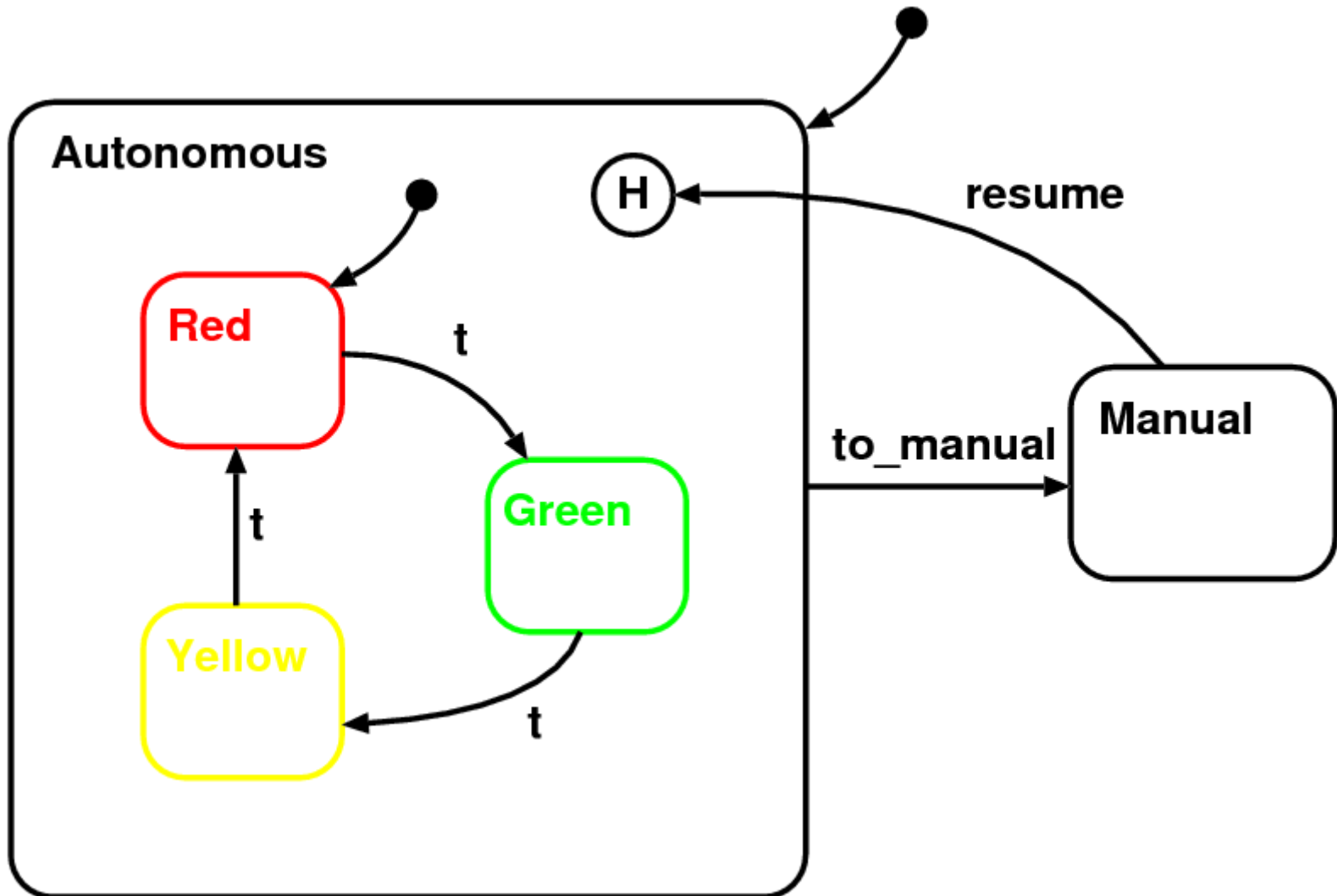

Deep History

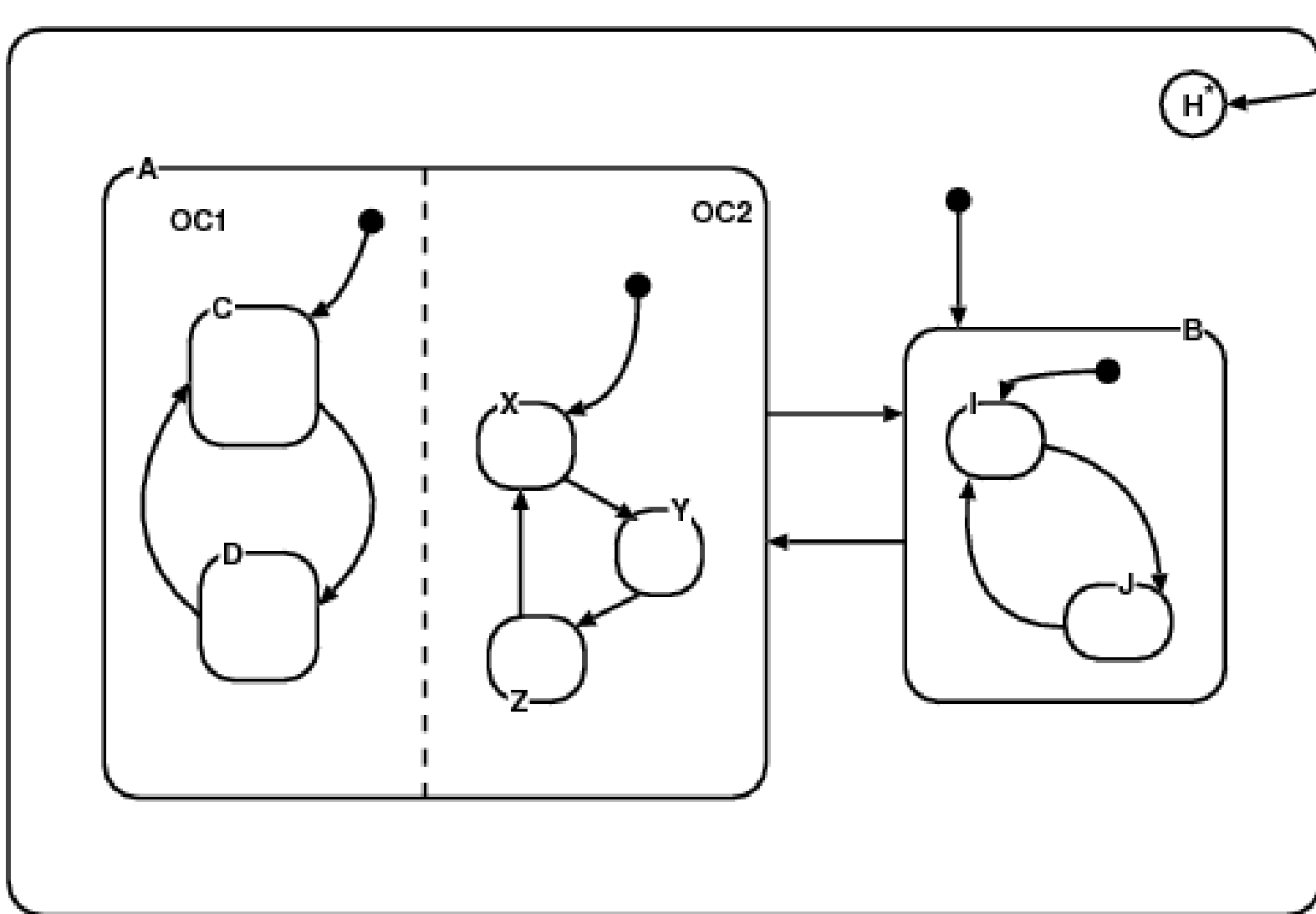

Stop Watch

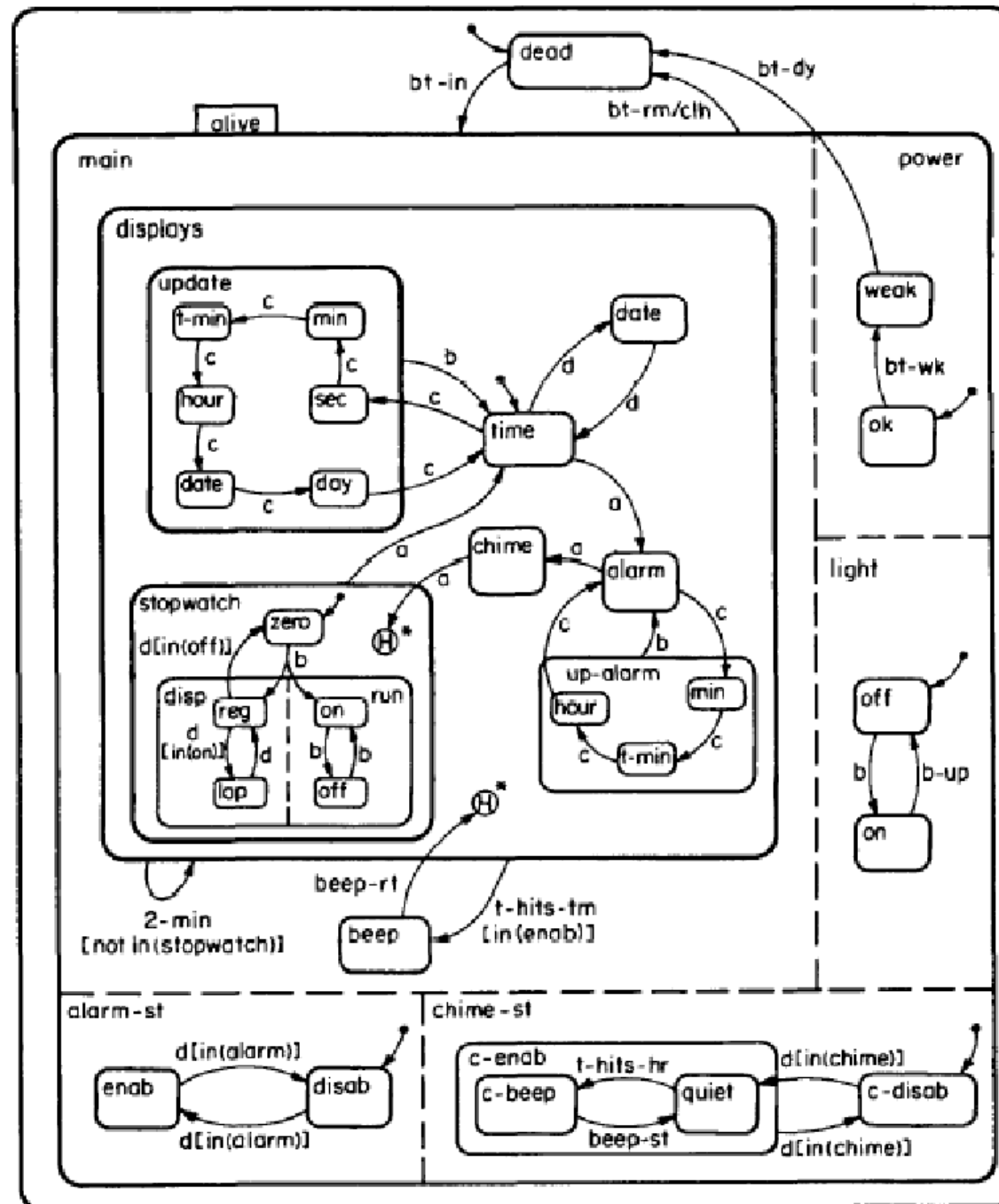

Traffic Light

- A traffic light has a green, a yellow and a red light.
 - ◆ Lights can be on and off
- The traffic light has a normal mode of operation.
 - ◆ At first, the green light it on.
 - ◆ After 0.5 sec, the green light turns off and the yellow light turns on
 - ◆ After 0.2 sec, the yellow light turns off and the red light turns on
 - ◆ After 0.7 sec, the red light turns off and the green light turns on
- A police offer can switch the traffic light into and out of emergency mode.
 - ◆ In emergency mode, the yellow light blinks every 0.5 seconds.
 - ◆ When exiting emergency mode, the light goes back to it's normal operation.
- The traffic light can be turned off and turn on again.
 - ◆ When turned back on, the traffic light resumes the previous mode of operation.