



# Modelica 3D-Thermal Library

---

Chahé Adourian, Corey Bolduc  
MSDL 2009 Summer Presentations  
McGill University  
Aug 27<sup>th</sup> 2009



# Outline

---

- Project Objectives
- Background on Thermal modeling
- Comparison and Gap
- Library components
- Future Work
- Conclusion



# Project Objectives

---

- Multi-disciplinary Modeling and simulation of satellite subsystems including:
  - Multi-body dynamics & Control systems
  - Command and Telemetry
  - Budgets Simulation
    - Processor Activity
    - Memory activity
  - Power subsystem
  - **Thermal Subsystem (this presentation)**
- Thermal modeling Requirements
  - Block Diagram Modeling
  - Support 1D, 2D, 3D thermal models
  - Use of the Modelica language

# Project Objectives

## Required Features

- Device-based decomposition
- 3D Thermal subcomponents

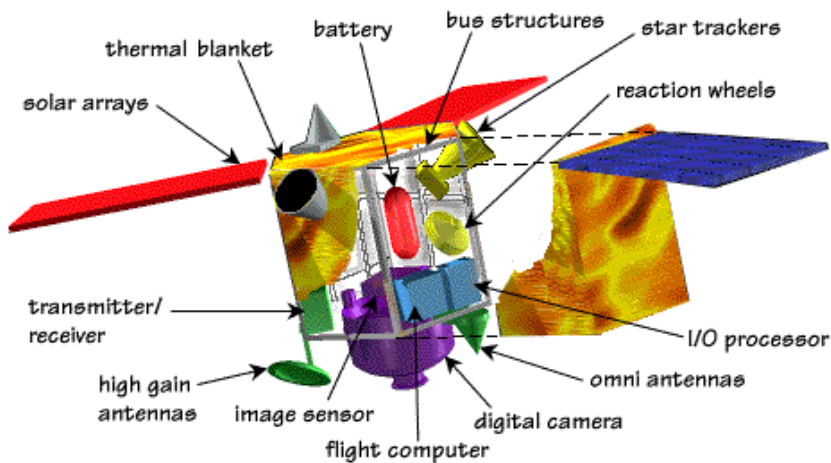

- Command & Data
- Power Supply
- Pointing Control
- Mission Payload
- Communications
- Thermal Control

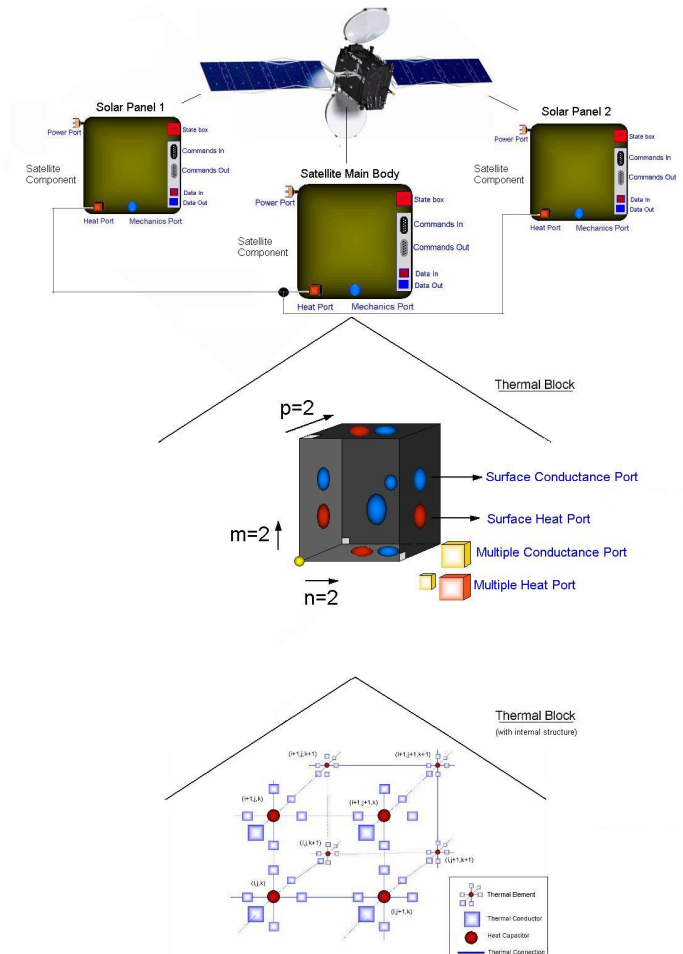



# Background – Thermal Modeling approaches

---

- Current Thermal Modeling approaches
  - Mainstream CAD-based Finite Element Analysis (FEA)
    - ANSYS
    - CATIA
    - ...and many others
  - 1D, 2D approaches
    - Example from Modelica Thermal Library

# Background – CAD Based Finite Element Analysis

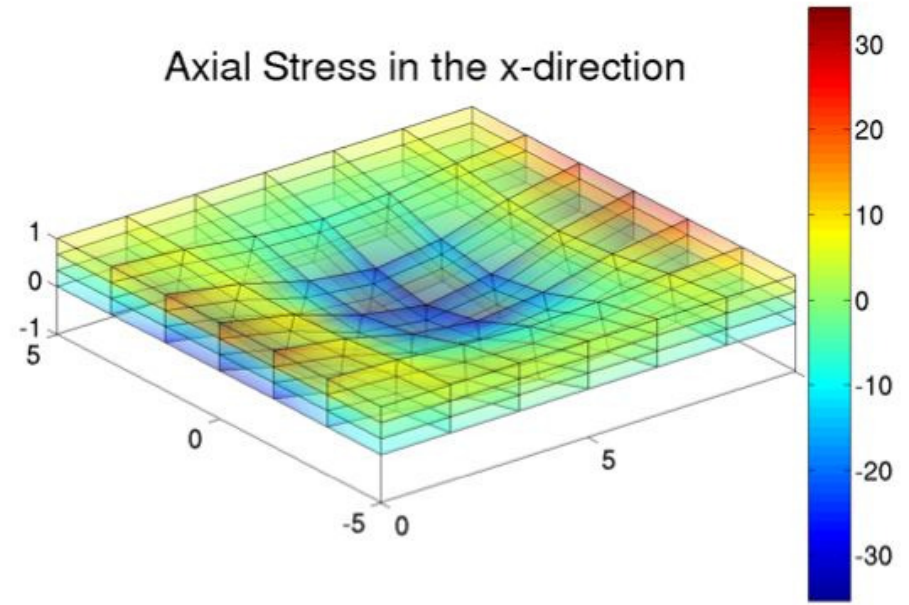
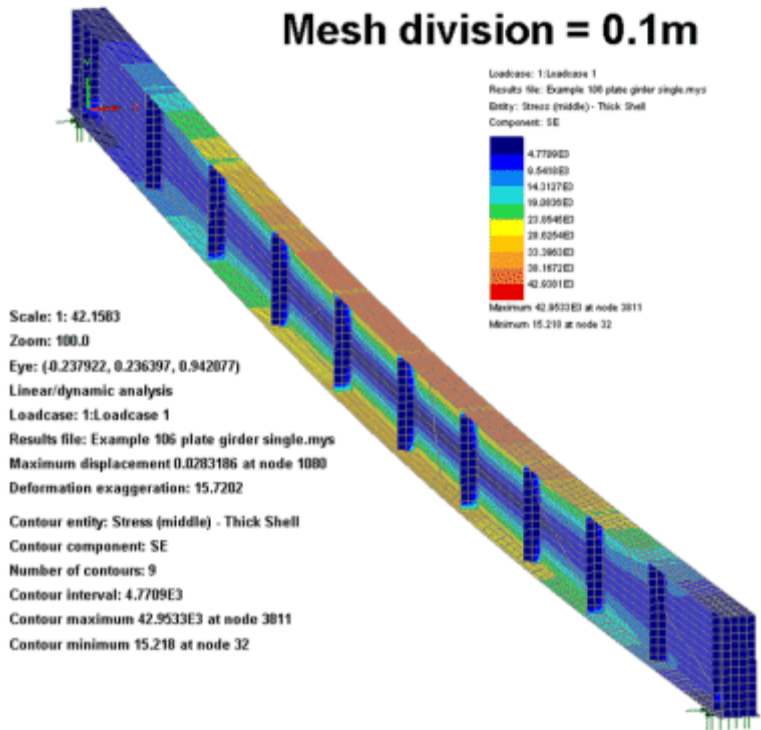

# Background – CAD-Based Finite Element Analysis



CAR Model

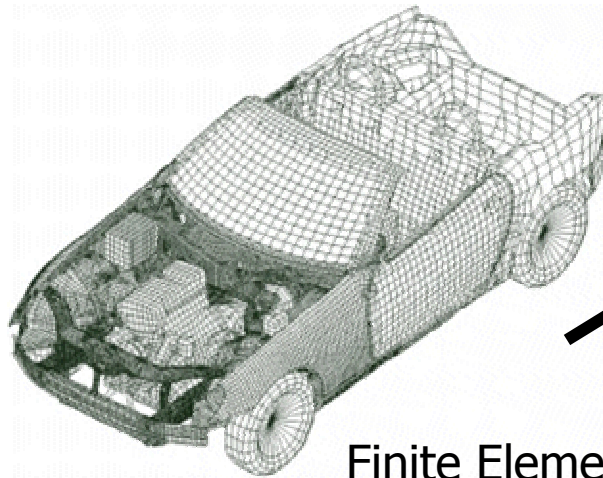
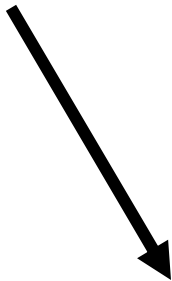

Finite Element  
Model

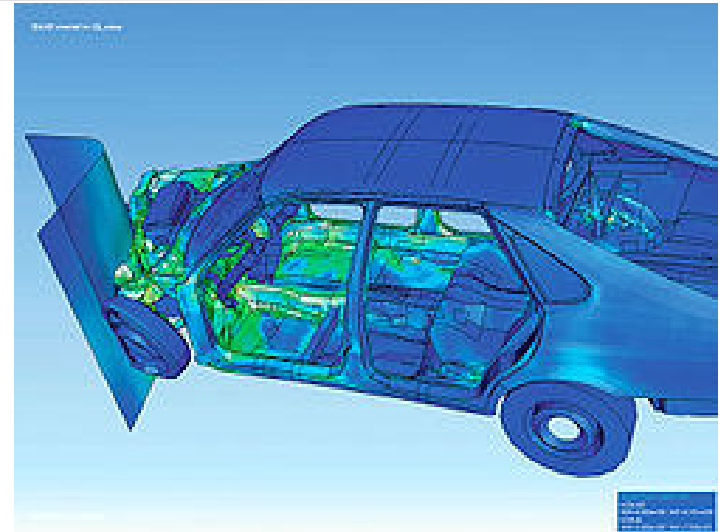

Resulting Simulation

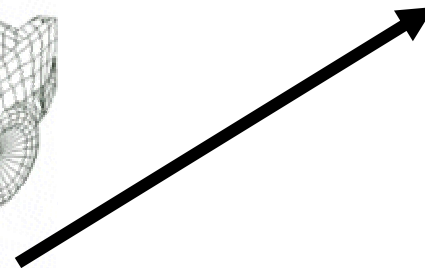

# Background – Block Diagram based 1D,2D Models

- Thermal conduction between two masses

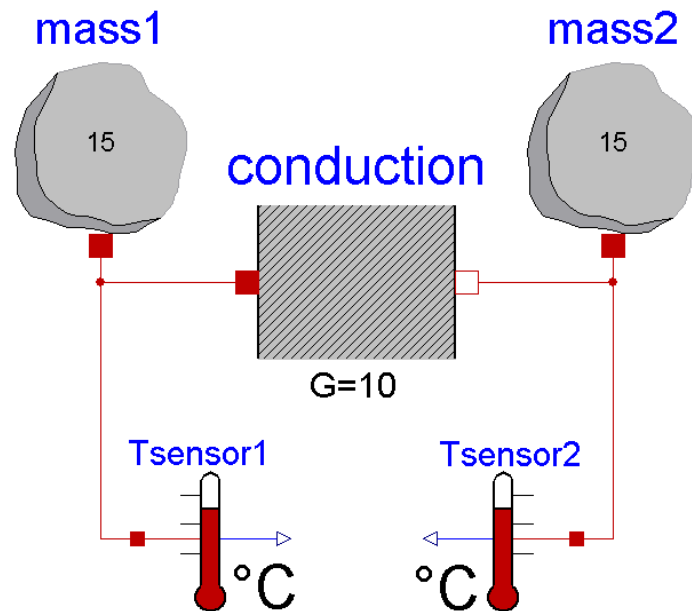



# Background – Block Diagram based 1D,2D Models

---

- Components (Partial list)
  - Heat Capacitors
  - Heat Conductors
  - Sources
    - Temperature
    - Heat

# Background – Block Diagram based 1D,2D Models

- Thermal Model of a Plate

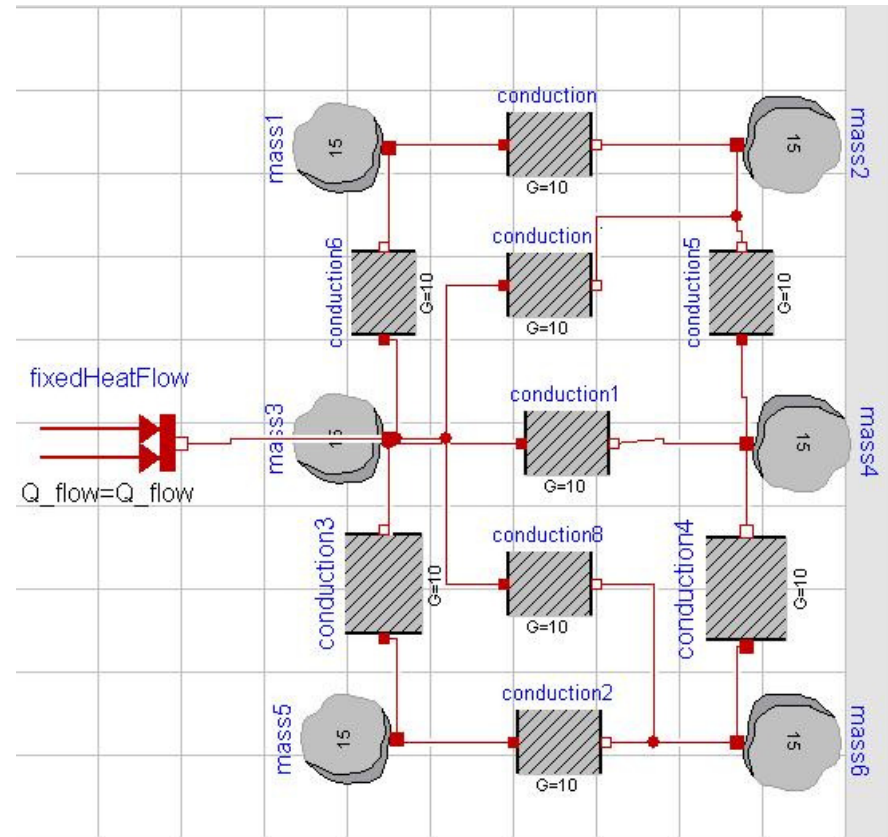

# Comparison and Gap

- Current approaches
  - CAD-FEA Approach

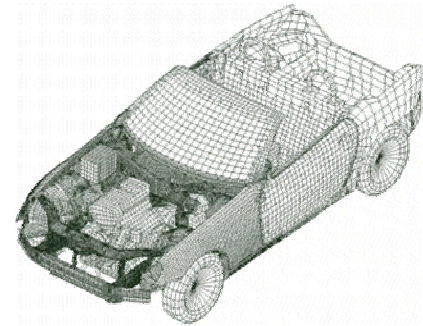

- Block Diagram 1D,2D

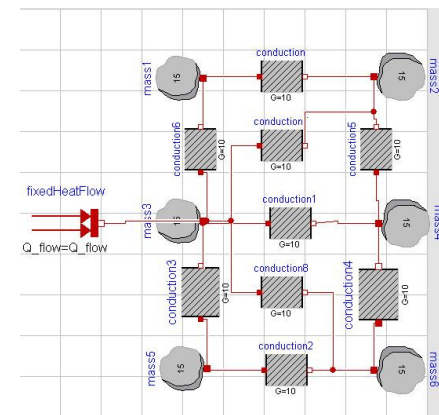



# Comparison and Gap

---

- Proposed approach
  - Have Intermediate capability between
    - 1D, 2D and
    - CAD-based approaches
  - Be Block-diagram based
  - Capable of limited 3D thermal modeling
  - Integrates with multidisciplinary simulation models (Modelica)

# Comparison and Gap

- 3D block-diagram based Thermal decomposition

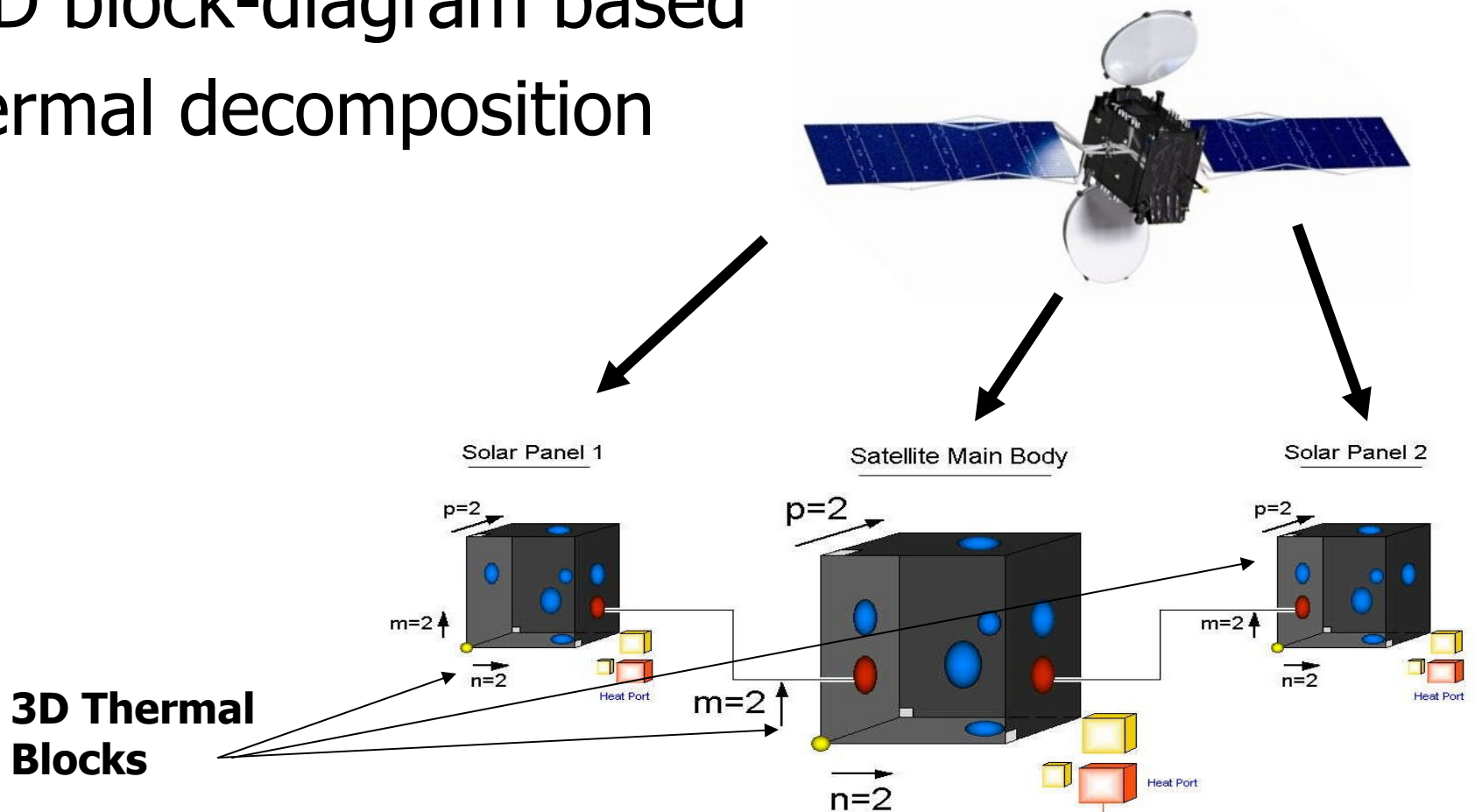



# Library components

---

- 3D Thermal Element (Basic building block)
- 3D Thermal Block
- Interfaces
  - 2D Surface interface
  - 3D Volume Interface

# Library components – Thermal Element

- Physical equivalent
  - A Cube
- Model Components
  - One Capacitance
  - Six Conductances
  - Other interfaces

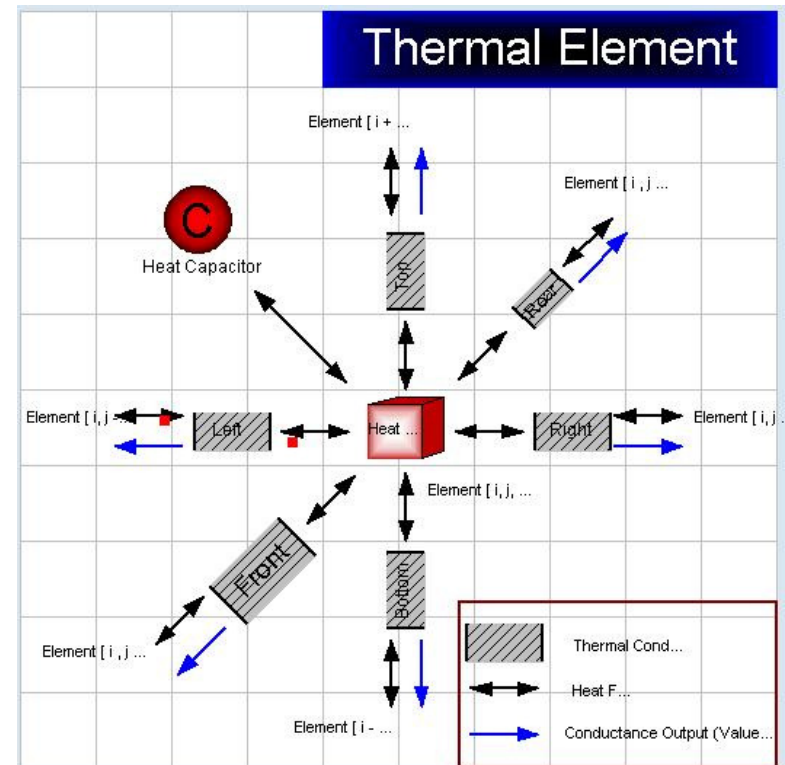

# Library components – Thermal Element

- Model &
- Interfaces

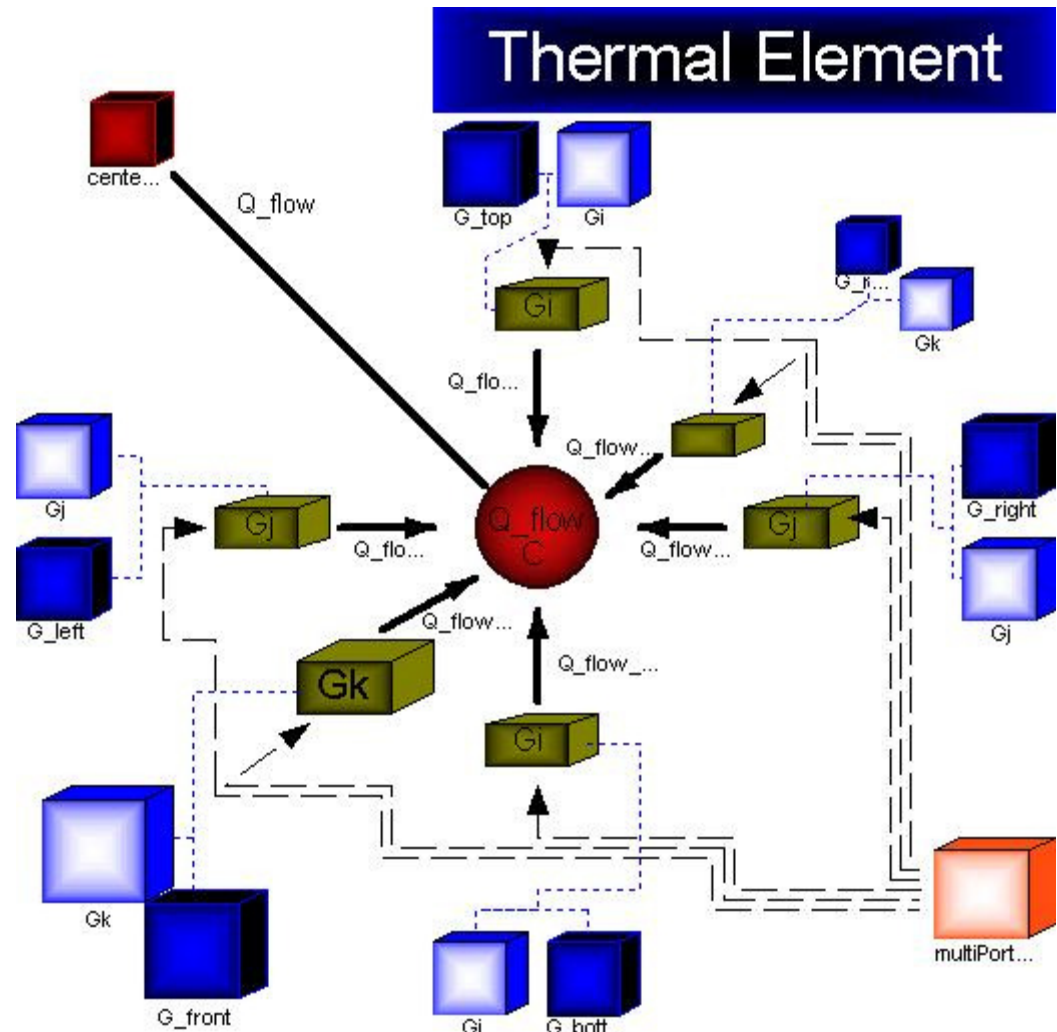

# Library components – 3D Thermal Block

- Physical Equivalent: An extended cube
- Model components:  $M \times N \times P$  Thermal elements

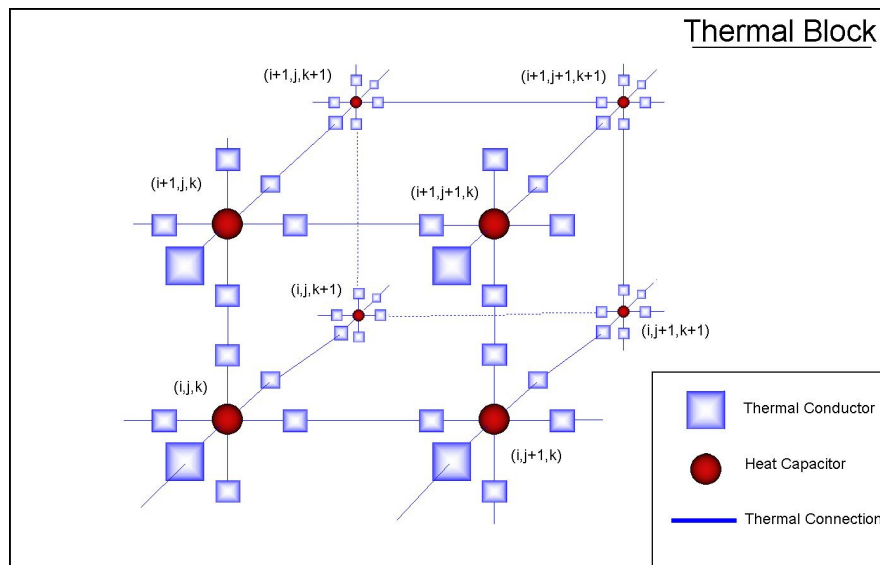

**Internal Composition**

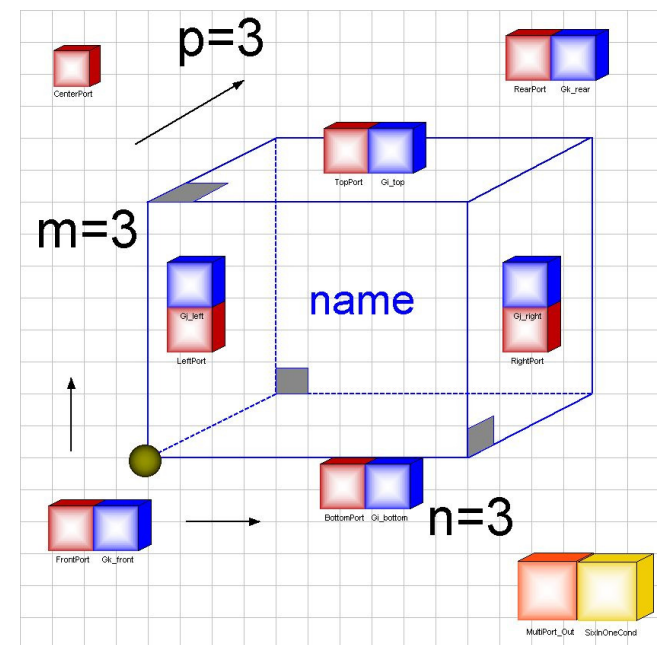

**External User Interface**

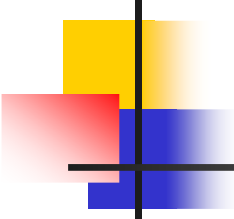

# Library components – 3D Thermal Block

---

- Properties
  - Material property distribution specified
  - Cavities can be modeled
  - Connections possible to internal elements
- Potential applications
  - Model objects which are composed of different materials
  - Connect internal elements to external temperature of heat sources



# Library components – Surface Interface

---

- Requirements
  - Thermally connect two surfaces
  - Adjust for differences in mesh resolution
  - Apply discrete rotations (0,90,180, 270 degrees)
  - Insert surface contact resistance

# Library components – Surface Interface

- Illustration of connection details

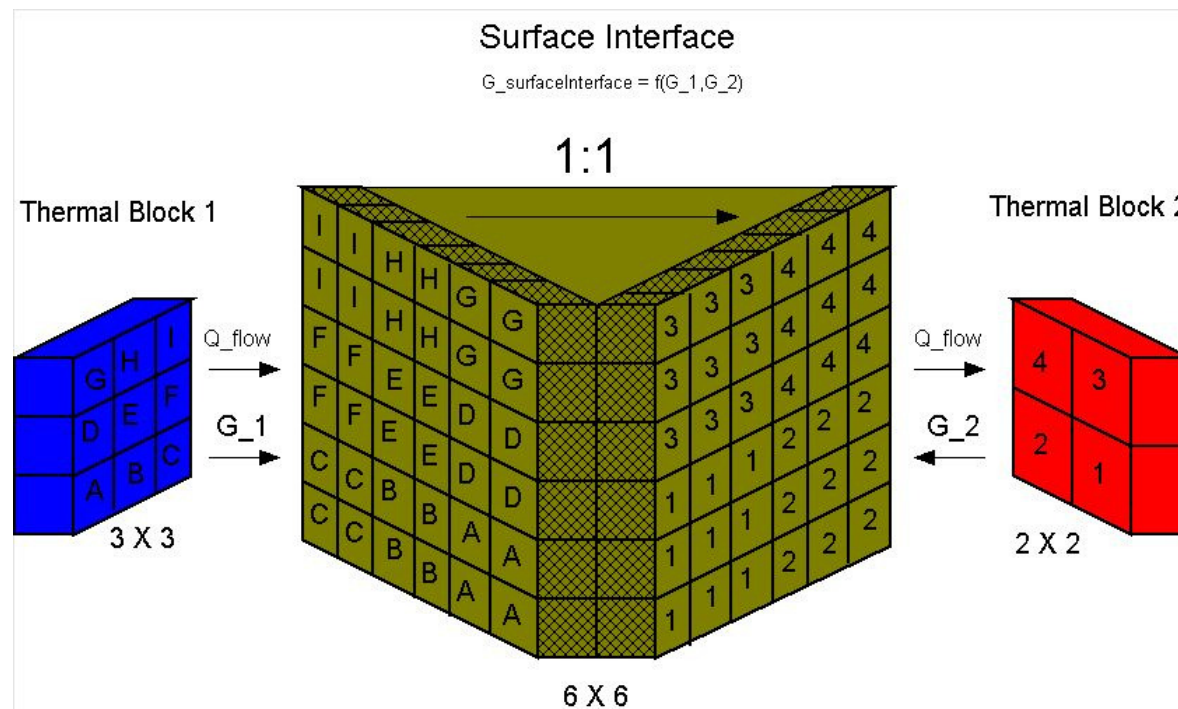

# Library components – Surface Interface

- Modelica example
  - Single surface connection

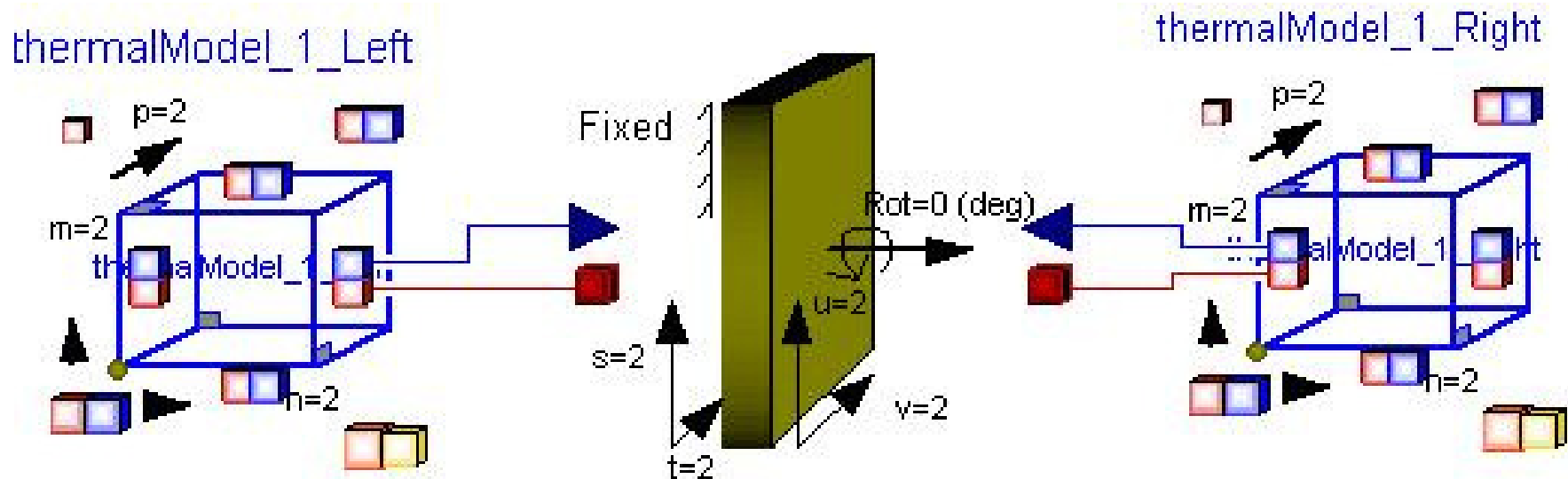

# Library components – Surface Interface

- Example application
  - Connect plates on their sides to each other

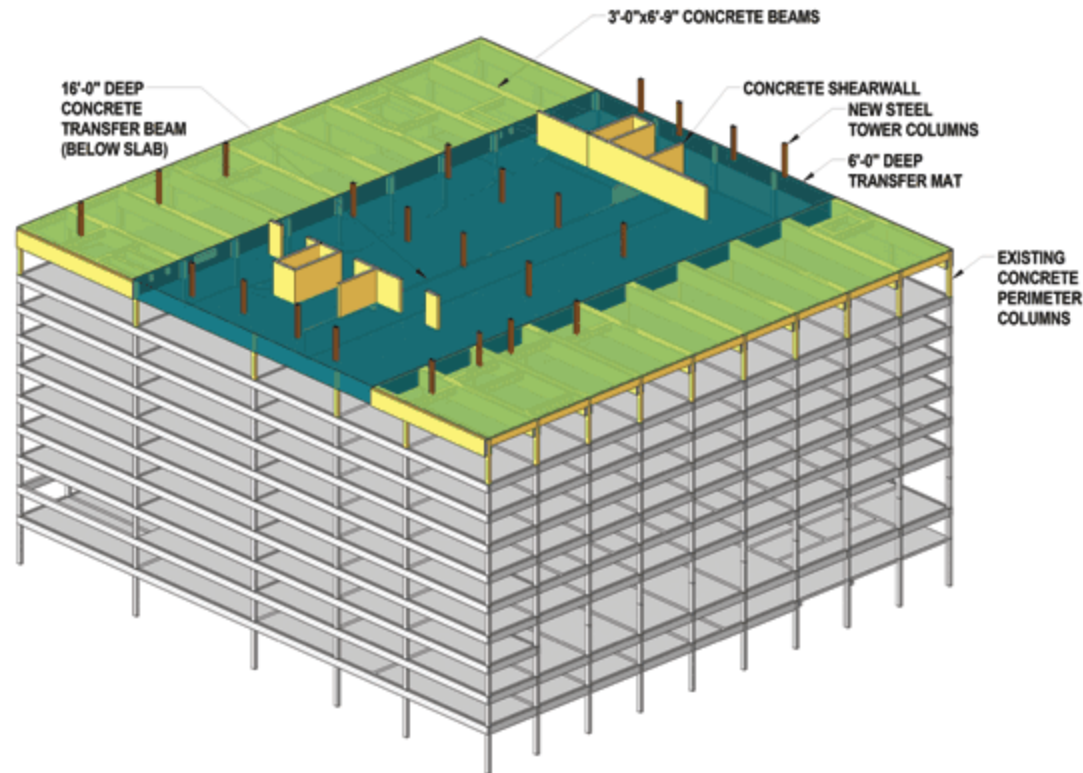

# Library components – 2D Surface Interface

- Example applications
  - Satellite trays

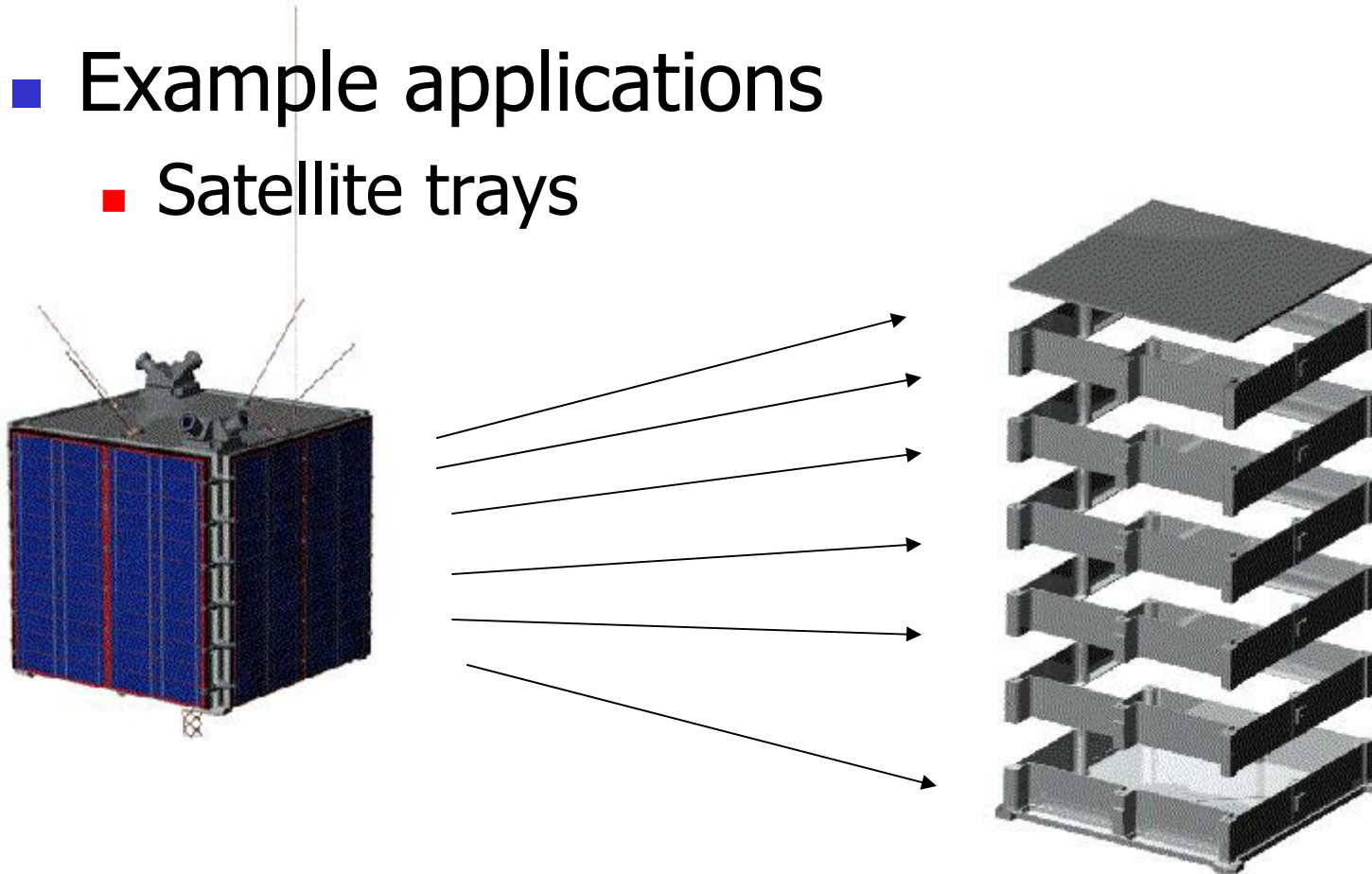



# Library components – 3D Volume Interface

---

- Requirements
  - Insert a Cube into another cube
  - Adjust for differences in mesh resolutions
  - Handle all thermal connections in a simple manner
- Assumptions
  - A container must have an internal cavity

# Library components – 3D Volume Interface

- Illustration of connection details
  - Six surfaces mapped inside the container

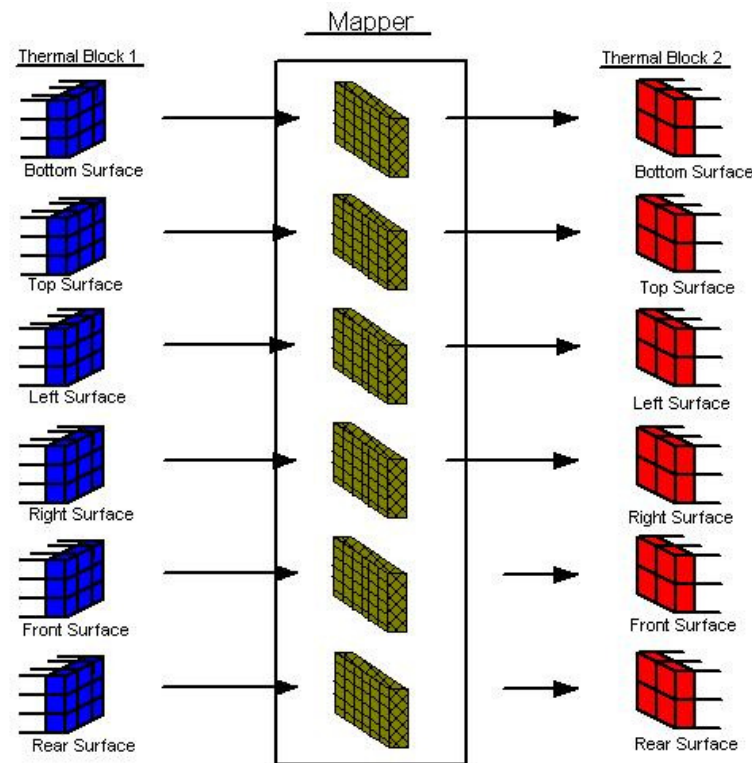

# Library components – 3D Volume Interface

- Example
  - Inserting one plate in another

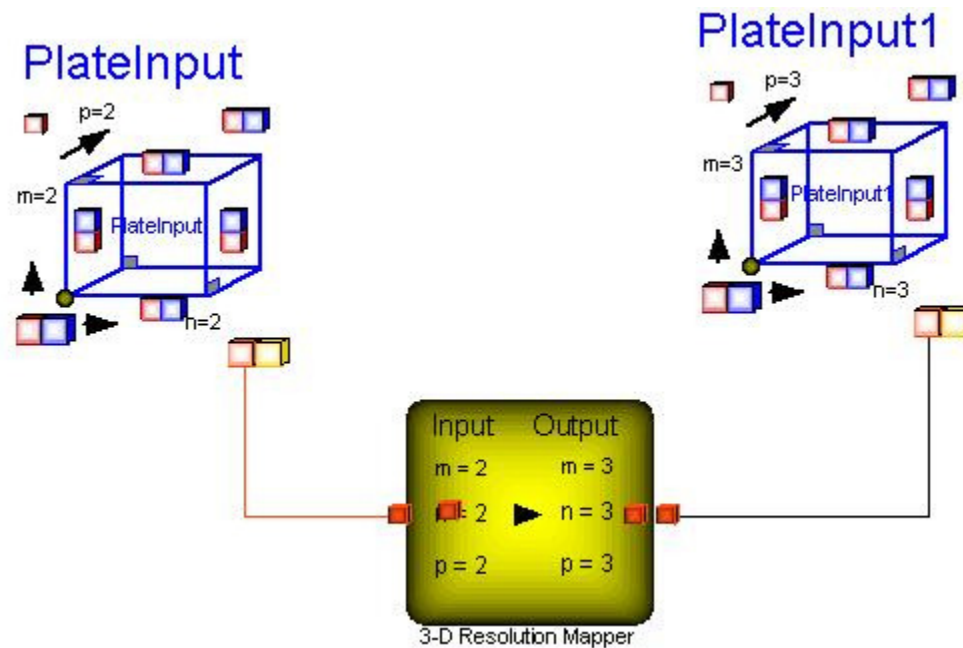

# Library components – 3D Volume Interface

## ■ Example applications

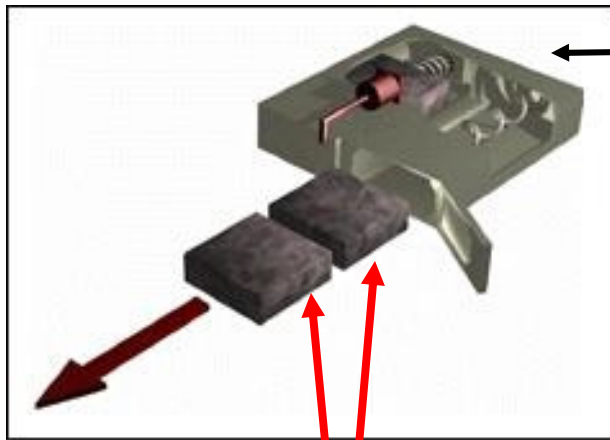

**Inserted Objects**

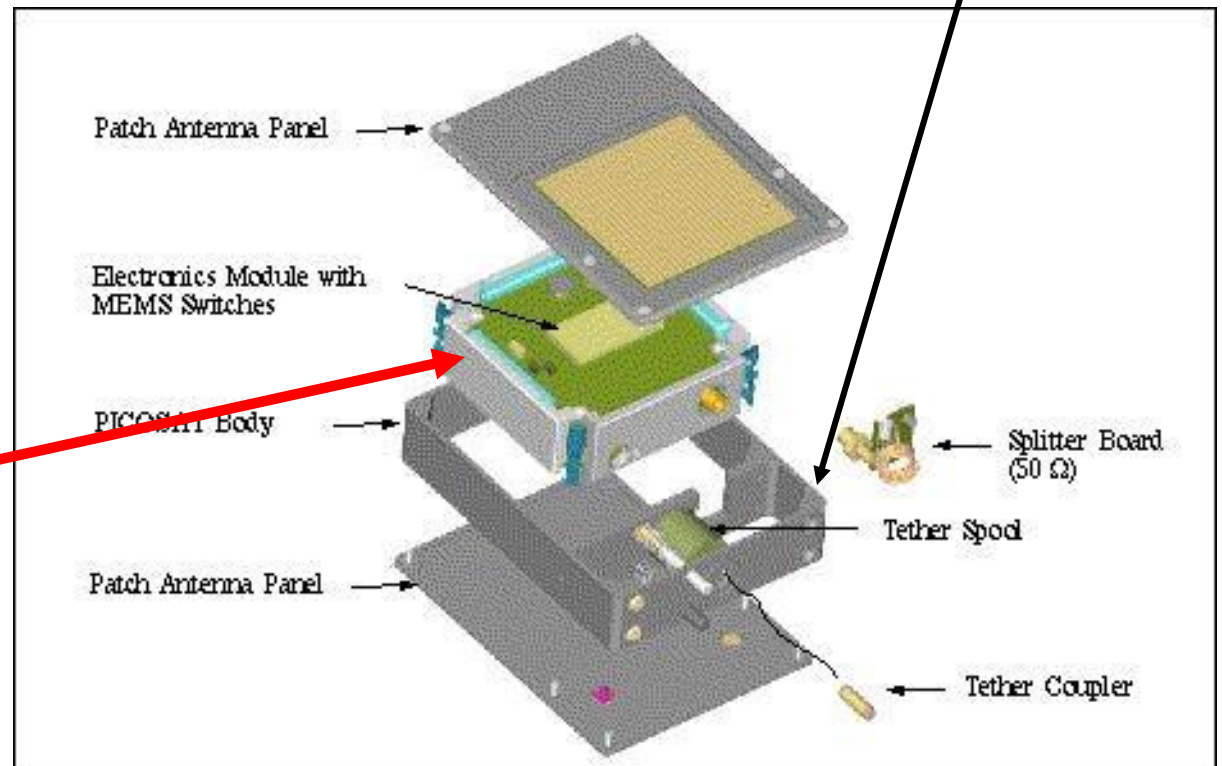



# Matlab Visualization

---

- Modelica inadequate for 3D visualization
- Developed Matlab extractors of Modelica results
- Developed 3D visualization code for
  - temperature
  - heat flow
  - Density distribution

# Matlab Visualization

- Example surface temperature distribution in a single cube

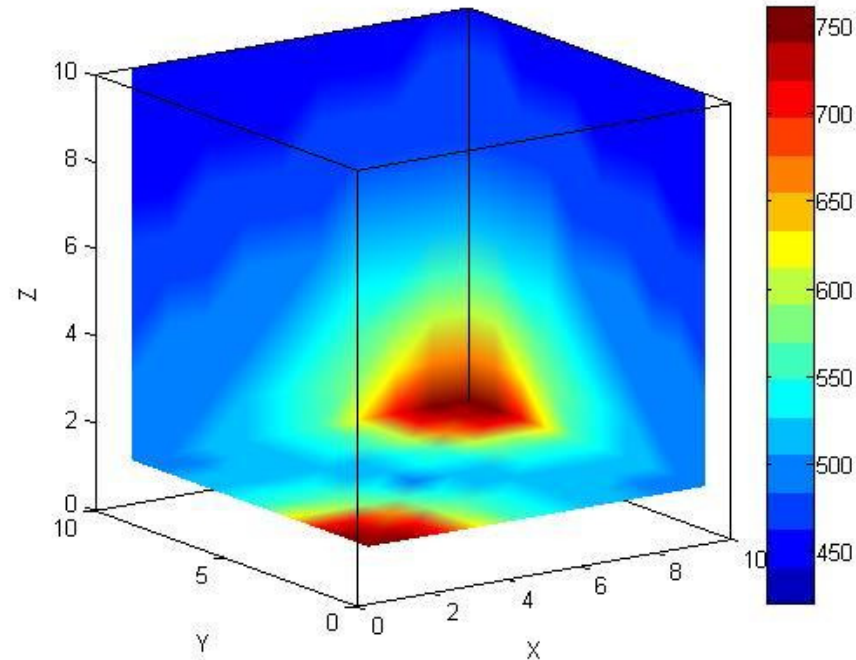



# Conclusions

---

- Status
  - Partially successful
  - Usability to be improved
  - 3D mapper still experimental
- Use of Modelica language
  - Language too restrictive
  - Difficult/cryptic to debug
  - Limited flexibility of User-interfaces
  - 3D Data Visualization missing
  - Required too much effort to reach current development levels



# Q & A

---

- Questions?