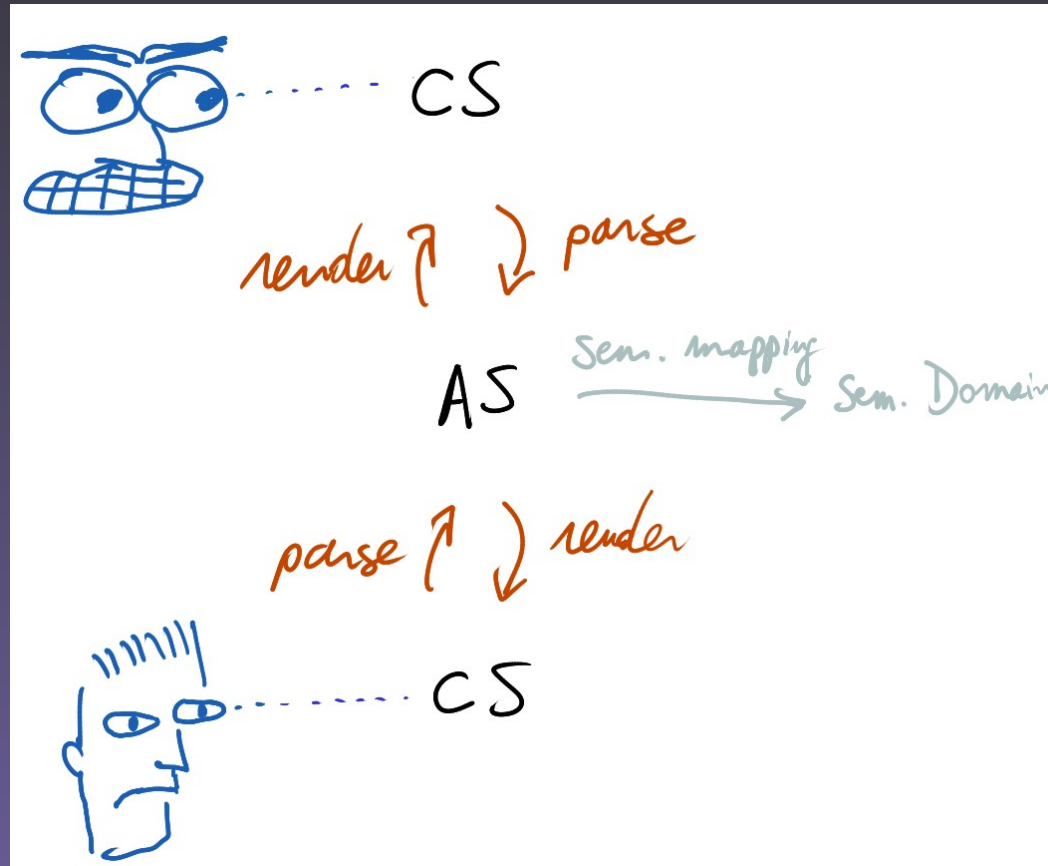
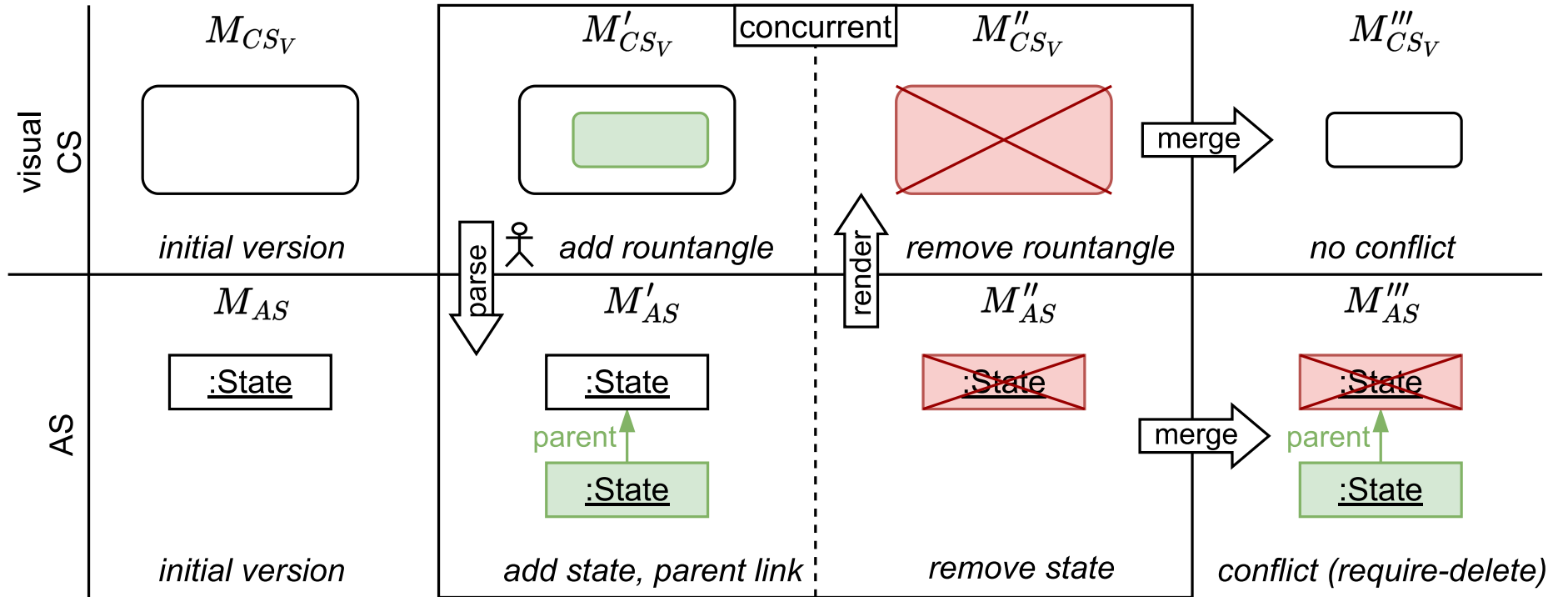

Fig. 3: Modelshare in our concrete syntax framework.

Blended modeling¹



¹Federico Ciccozzi, Matthias Tichy, Hans Vangheluwe, Danny Weyns: **Blended Modelling - What, Why and How**. MoDELS (Companion) 2019: 425-430



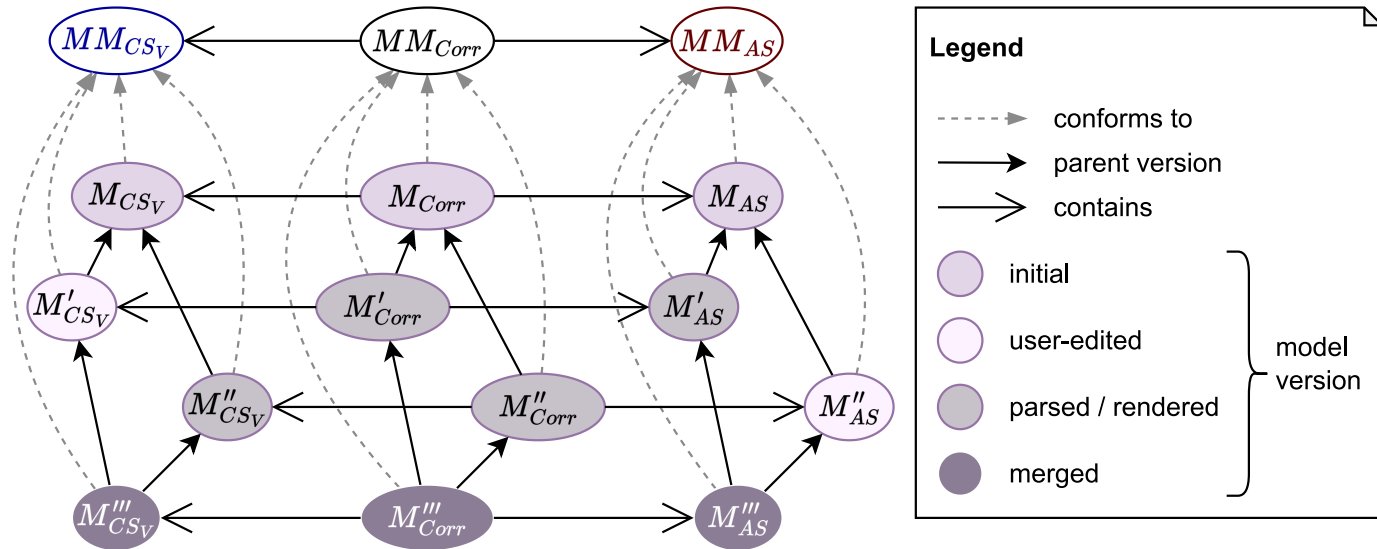
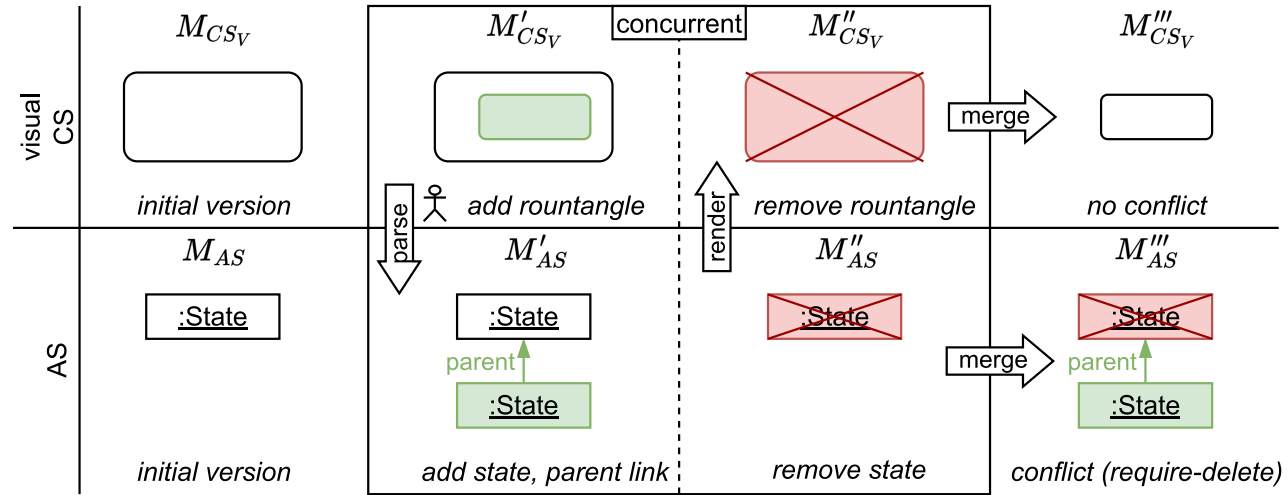

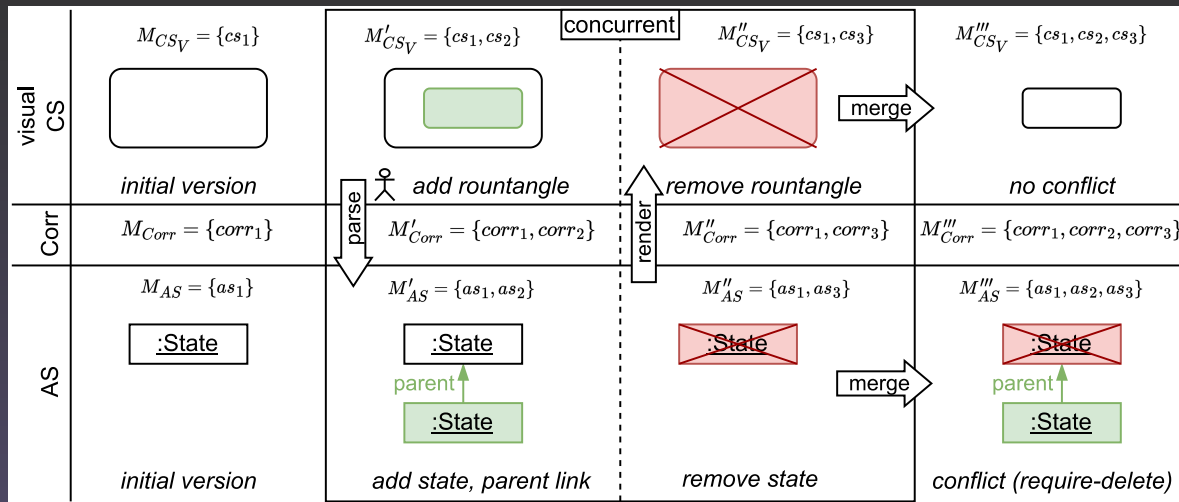

Visual CS

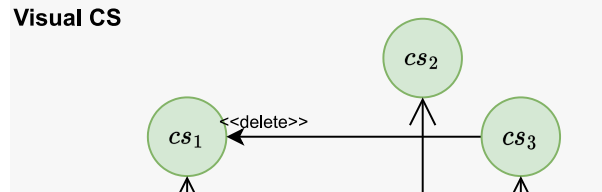

Corr

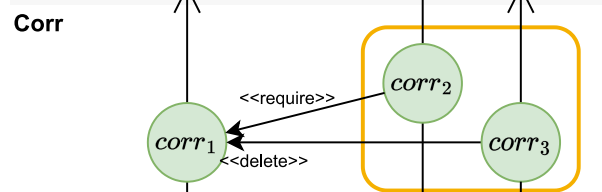

AS

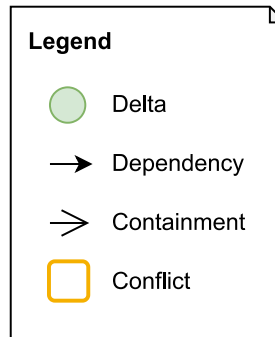
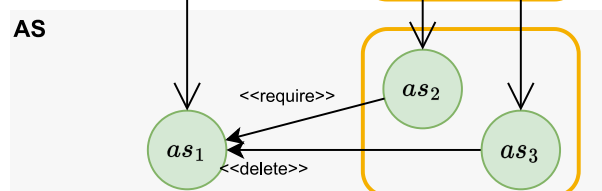

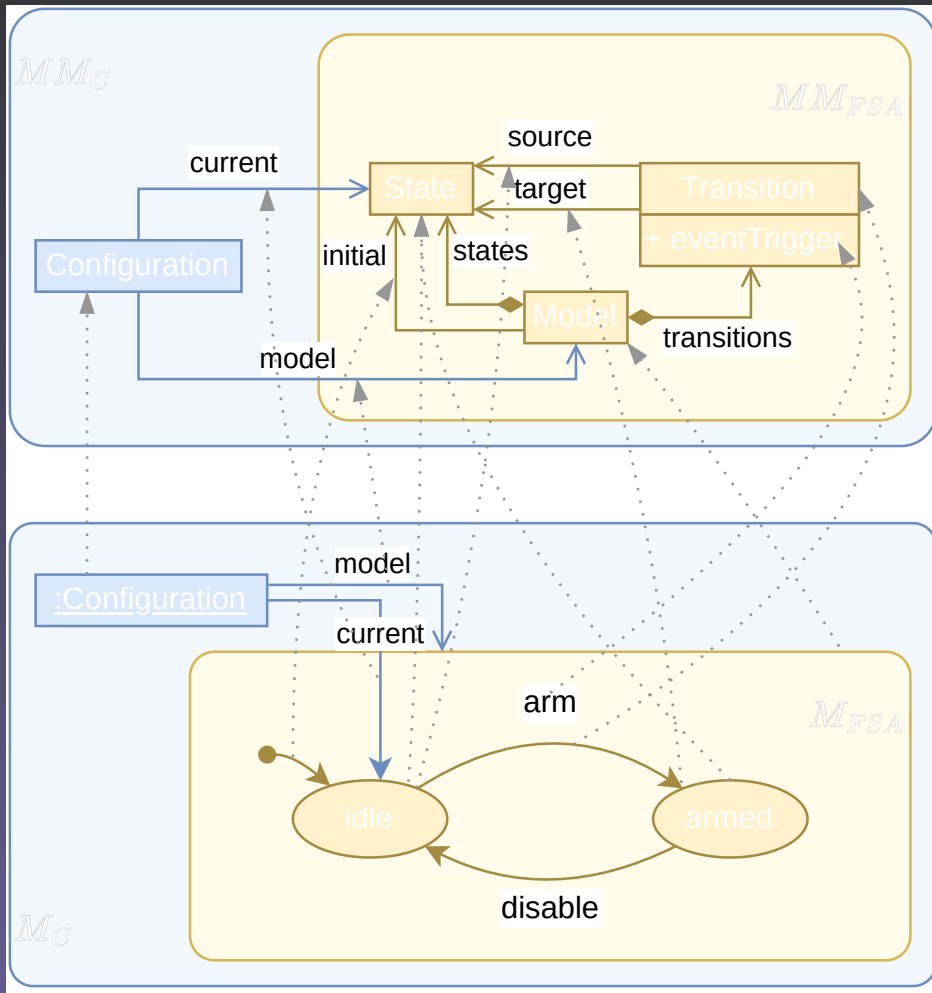

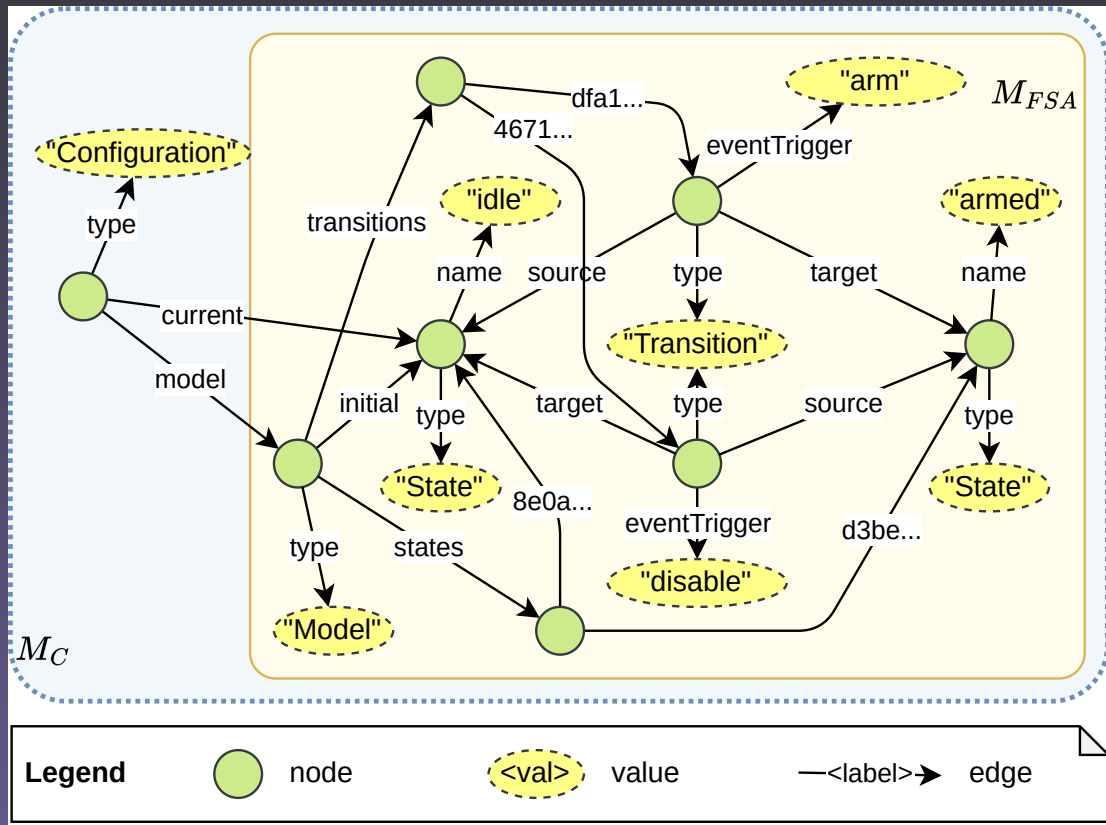
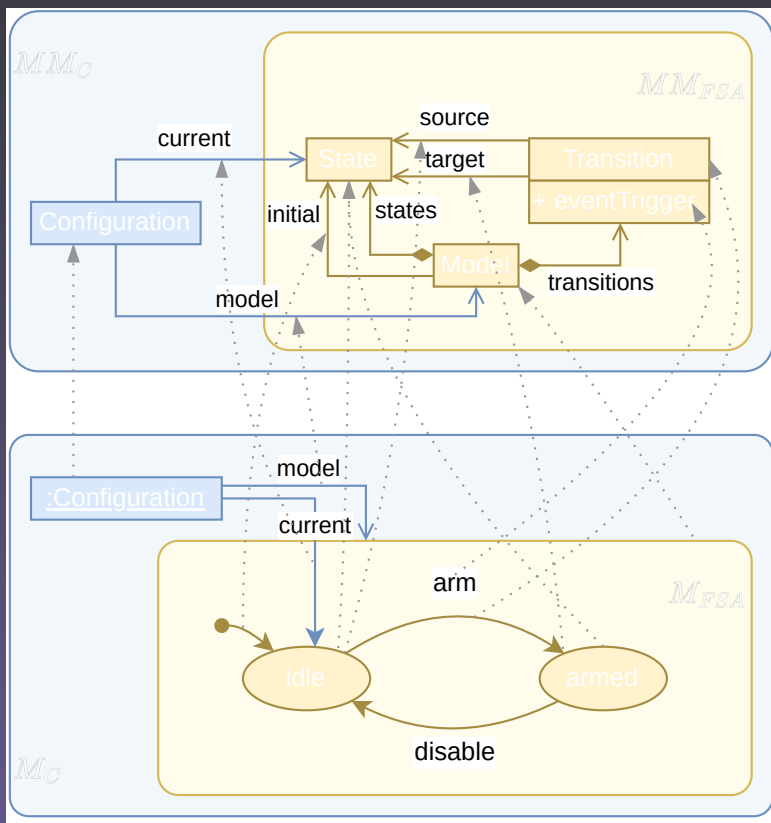

Additional benefits

- “Who set this variable”?
- Parallel independence
- Hibernating executions

Scalability issues to be addressed

- Collapsing long-running simulation traces

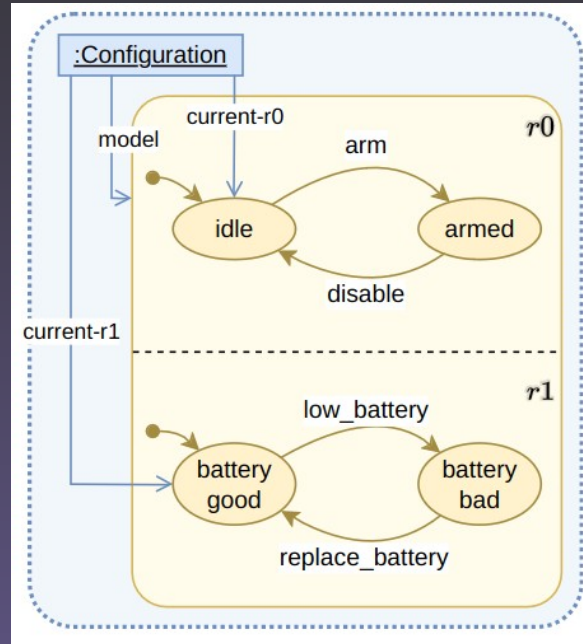

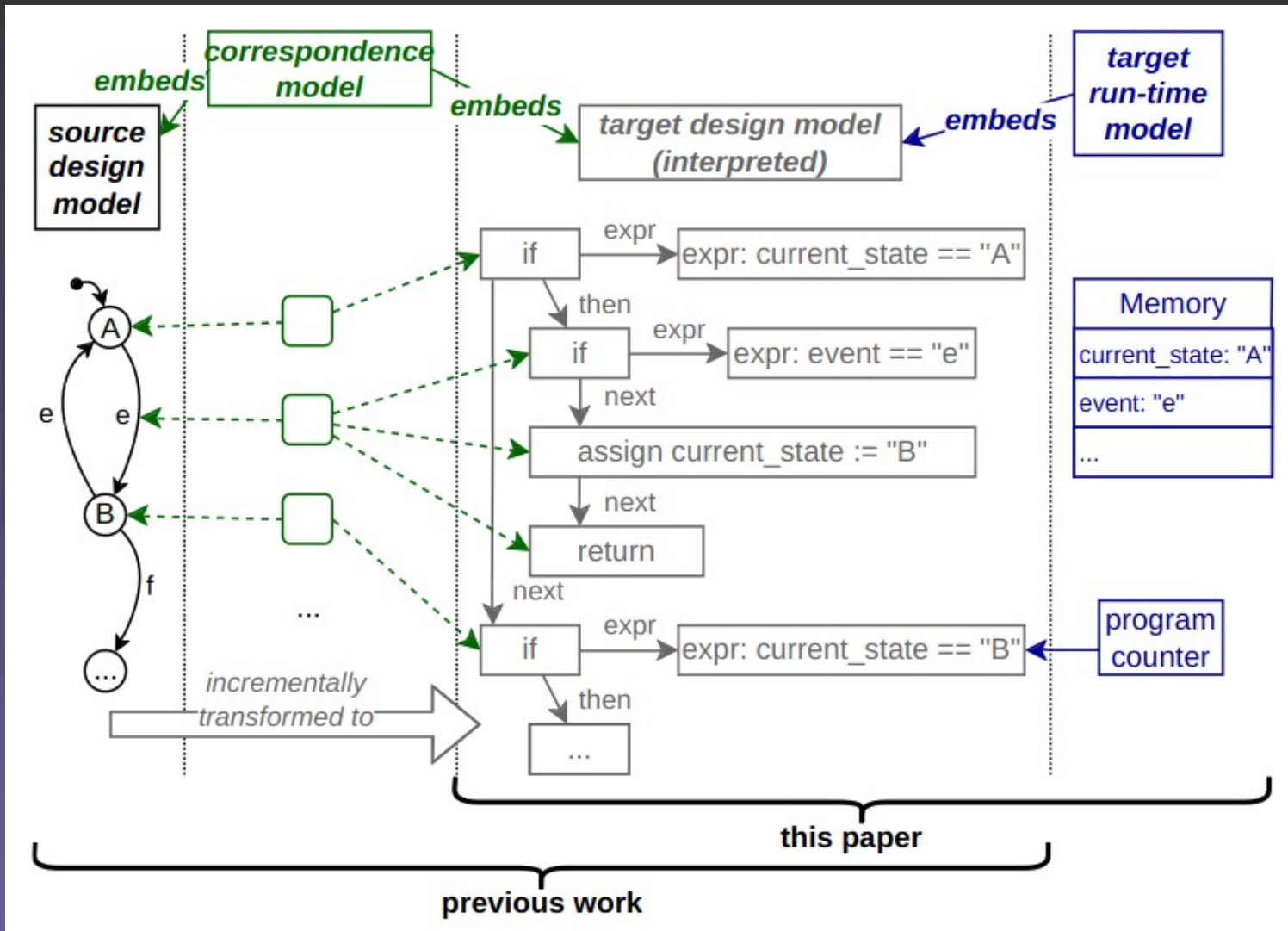

Collaboration, Debugging and Live Modeling

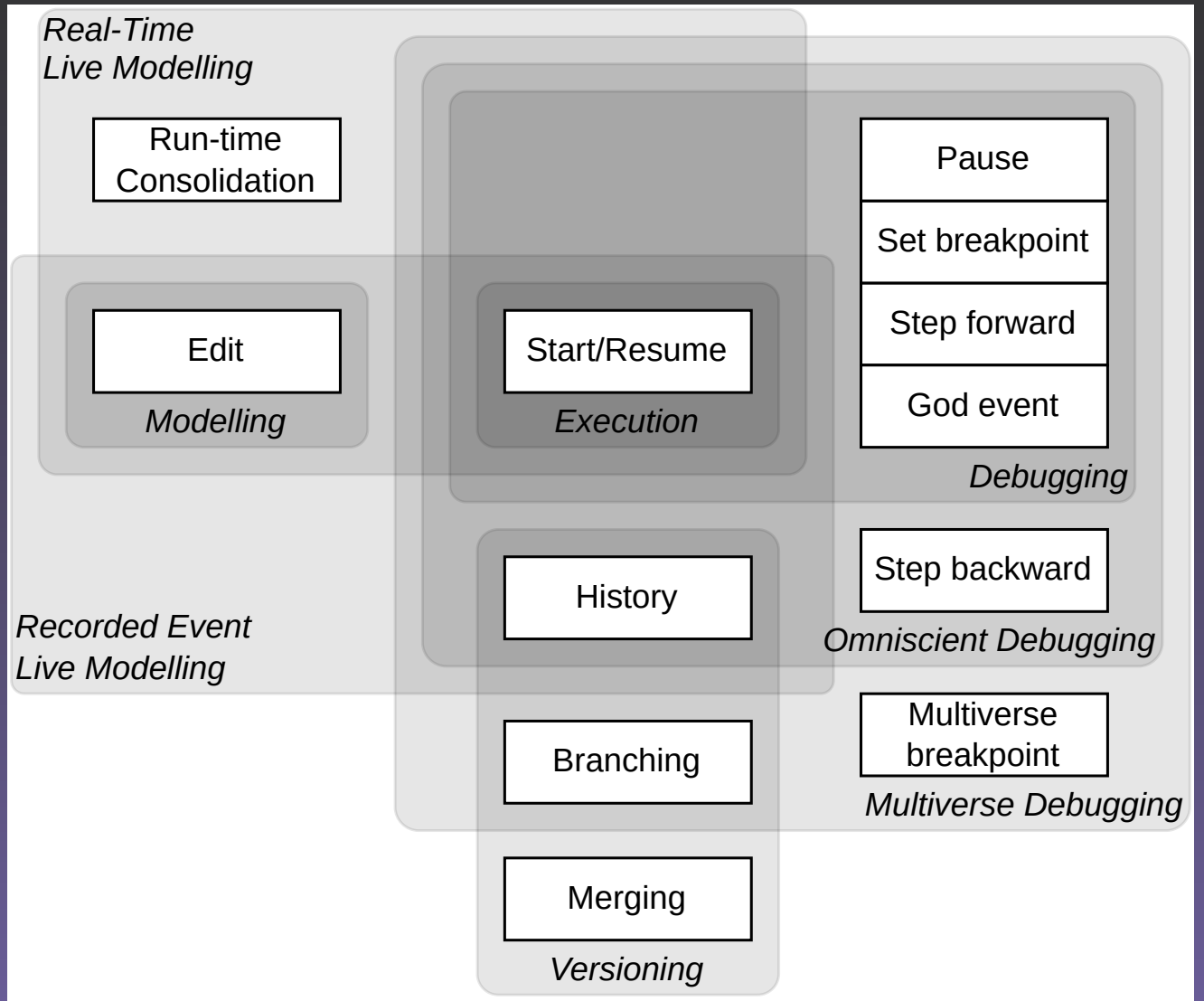

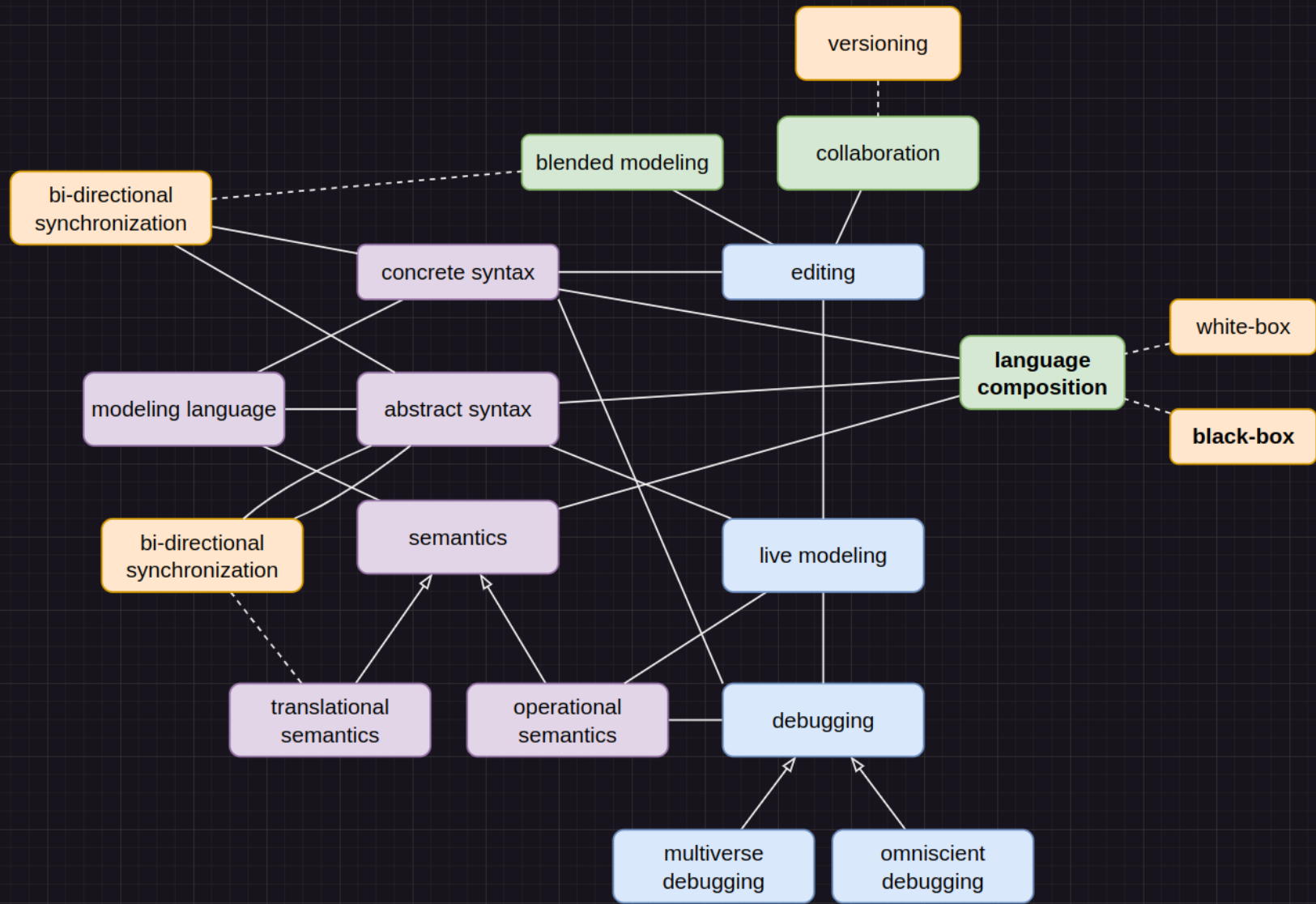

CBD within FSA

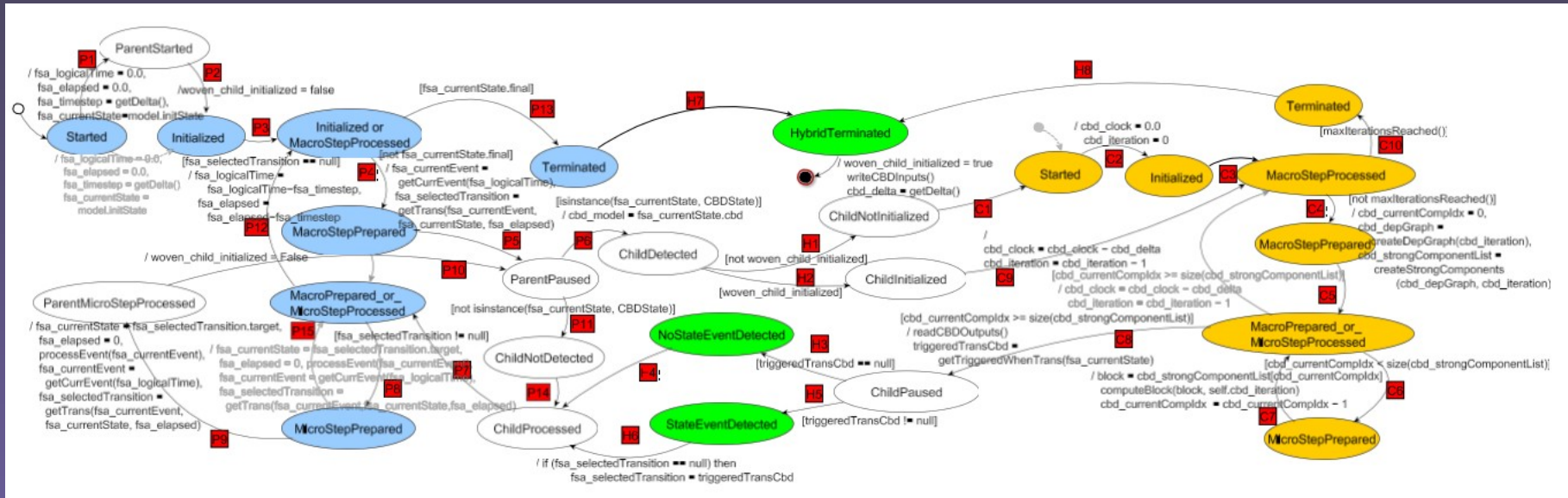
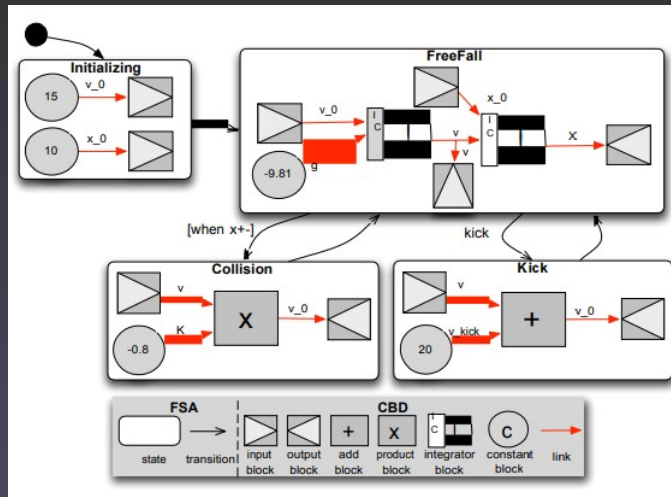

Statecharts

